

## ■エコスリム側溝本体

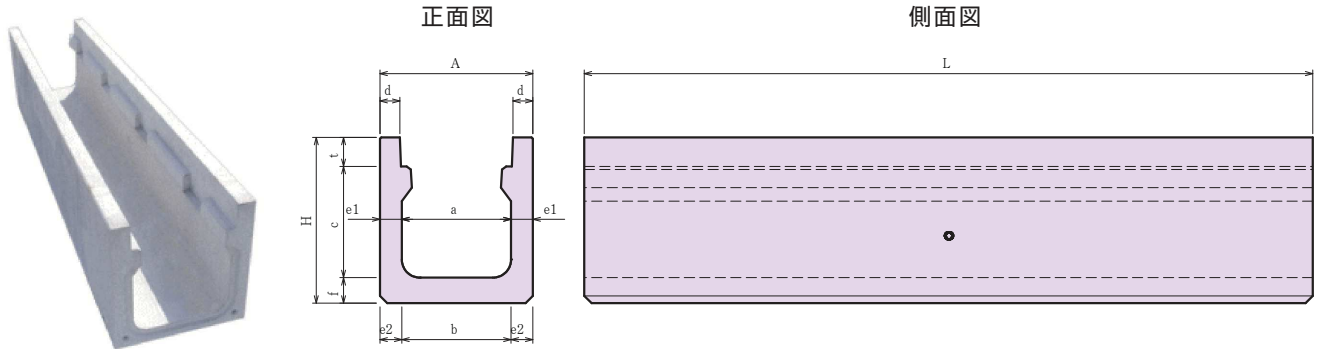

寸法表

呼び名	参考重量 (kg)	寸法 (mm)										
		A	H	a	b	c	d	e1	e2	f	t	L
250×250	305	360	400	250	250	255	50	55	55	65	80	2000
300×300	378	420	455	300	300	305	55	60	60	70	80	2000
300×400	451	420	560	300	280	405	55	60	70	75	80	2000
300×500	532	420	665	300	270	505	55	60	75	80	80	2000
300×600	620	420	765	300	260	605	55	60	80	80	80	2000
400×400	527	530	575	400	400	405	60	65	65	80	90	2000
400×500	590	530	675	400	400	505	60	65	65	80	90	2000
500×500	704	650	690	500	500	505	60	75	75	85	100	2000
500×600	800	650	790	500	480	605	60	75	85	85	100	2000
600×600	882	760	819	600	600	605	60	80	80	90	124	2000

## ■エコスリム側溝蓋

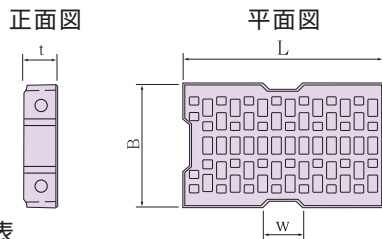

寸法表

呼び名	参考重量 (kg)	寸法 (mm)			
		B	t	W	L
250用	25	254	86	100	496
300用	30	304	86	100	496
400用	45	404	96	100	496
500用	65	524	106	100	496
600用	97	634	130	100	496

## ■エコスリム側溝 300×300(カーブ用)

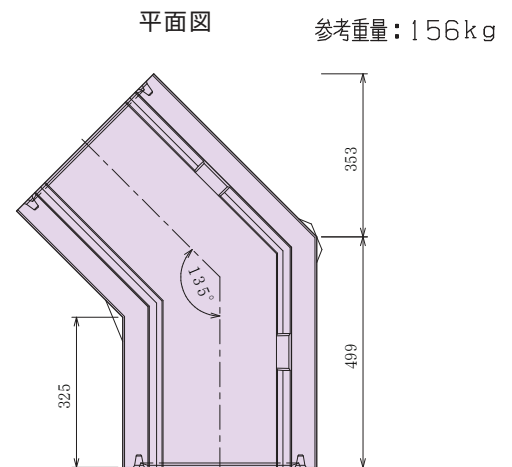

## ■エコスリム側溝集水蓋

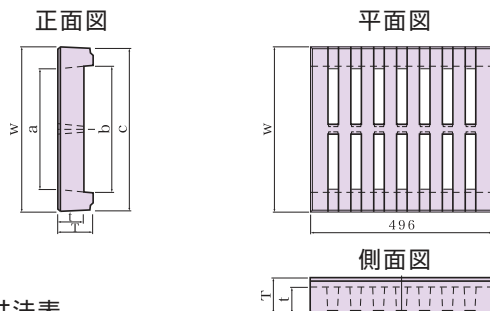

寸法表

呼び名	参考重量 (kg)	寸法 (mm)					
		W	a	b	c	T	t
250用	17	254	100	110	249	86	50
300用	19	304	100	110	299	86	50
400用	37	404	280	294	399	96	70
500用	41	524	350	364	519	106	75
600用	60	634	410	426	628	130	85

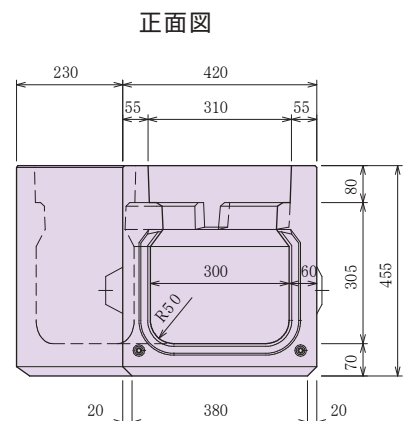

## I型 ノーマルタイプ

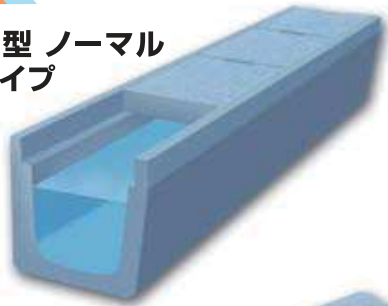

### 【エコノミー側溝の3大特徴】

#### ●設計面の特徴

JIS-A-5372-2004で要求されている、荷重に対しての使用状態性能・終局状態性能を満足する耐久性を有しています。(許容応力度法での設計も可)

#### ●機能面の特徴

- 1 流水断面底部を円形状にすることで、掃流性に優れ、流量も増加します。
- 2 蓋と本体の特殊接面構造により、外圧の分散機能と蓋の安定・消音が計れます。
- 3 側溝蓋の民地側を高くすることによって、道路排水の民地側への流出を防止します。
- 4 側壁片側を垂直に設計している為、境界が直壁となる部分にも施工できます。

#### ●施工面の特徴

製品のスリム化、軽量化を図り、運搬費・施工歩掛・工事日数が削減でき、コストダウンが図れます。

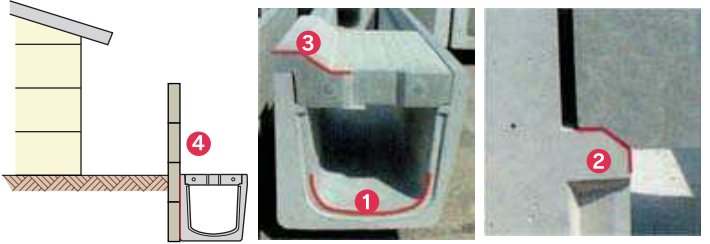

## II型 マウントアップタイプ

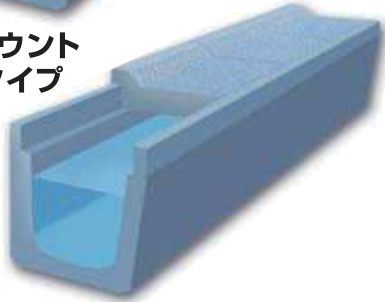

### ■エコノミー側溝本体

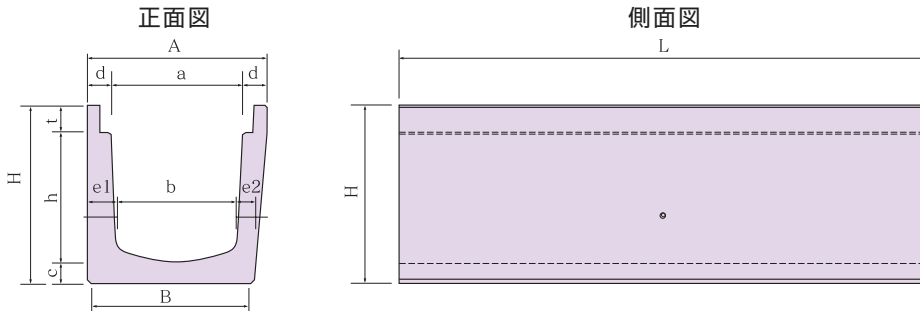

寸法表

呼び名	参考重量 (kg)	寸法 (mm)											
		A	a	H	h	B	b	c	d	e1	e2	t	L
250×250	294	390	250	385	250	316	230	55	70	80	50	80	1998
300×300	344	440	300	435	300	364	276	55	70	82	50	80	1998
300×400	427	440	300	540	400	366	268	60	70	86	55	80	1998
300×500	515	440	300	645	500	366	260	65	70	90	60	80	1998
400×400	492	540	400	555	400	471	368	65	70	86	60	90	1998
400×500	582	540	400	660	500	473	360	70	70	90	65	90	1998
500×500	751	680	500	675	500	590	450	75	90	115	70	100	1998

### ■エコノミー側溝蓋

#### I型

正面図

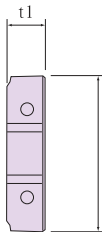

平面図

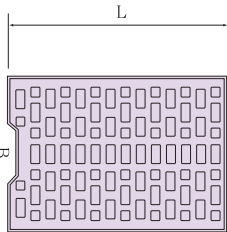

#### II型

正面図

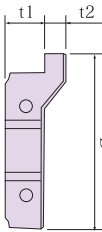

平面図

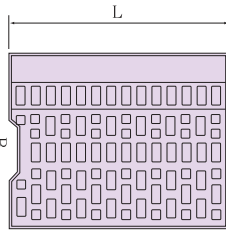

寸法表

呼び名	参考重量 (kg)	寸法 (mm)				
		B	t1	t2	L	
I型	250用	30	304	86	—	496
	300用	36	354	86	—	496
	400用	51	454	96	—	496
	500用	71	574	106	—	496
II型	250用	35	347	86	50	496
	300用	40	397	86	50	496

※グレーチング又は高強度集水蓋にも対応致します。

### ■エコノミー側溝集水蓋

正面図

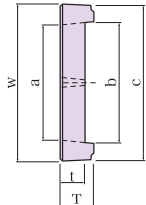

平面図

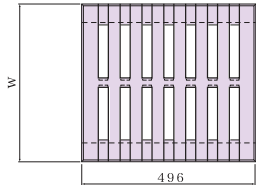

側面図



寸法表

呼び名	参考重量 (kg)	寸法 (mm)					
		W	a	b	c	T	t
250用	19	304	100	110	299	86	50
300用	21	354	230	242	346	86	50
400用	30	454	330	346	446	96	70

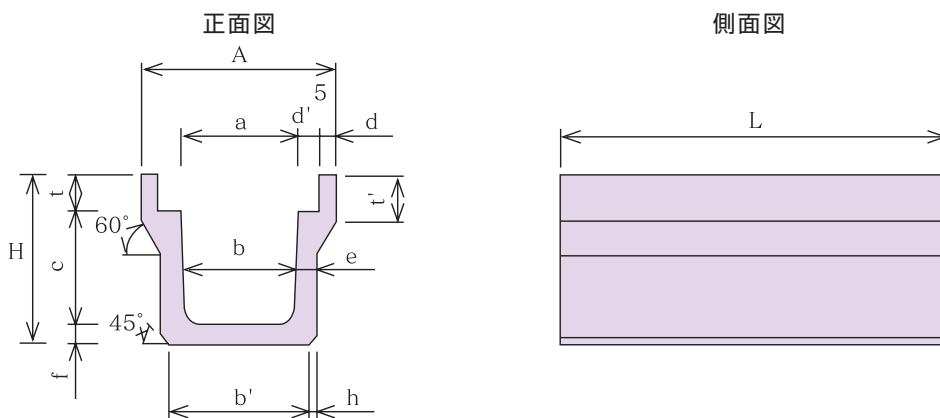

寸法表

呼び名	参考重量		寸法 (単位mm)												
	L=1000	L=2000	a	c	A	H	d	d'	b	e	h	b'	f	t	t'
250	141	282	250	250	450	390	40	55	230	55	20	300	50	90	120
300A	164	329	300	300	500	445	40	55	280	60	20	360	50	95	120
300B	200	401	300	400	500	550	40	55	270	65	20	360	55	95	120
300C	238	477	300	500	500	655	40	55	260	70	20	360	60	95	120
400A	216	433	400	400	600	565	40	55	370	65	20	460	55	110	135
400B	256	512	400	500	600	670	40	55	360	70	20	460	60	110	135
500A	282	565	500	500	720	685	45	60	460	70	20	560	60	125	150
500B	325	651	500	600	720	790	45	60	450	75	20	560	65	125	150

# KT側溝 1種蓋 (歩道用)

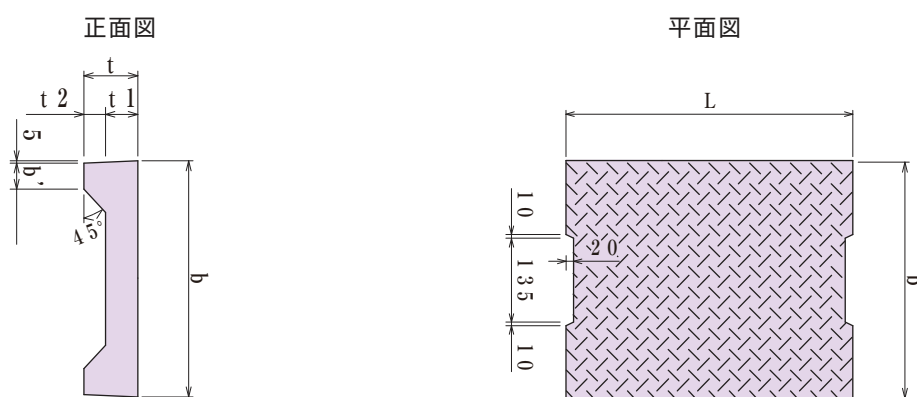

寸法表

呼び名	参考重量 (kg)	寸法 (mm)					
		b	b'	t	t1	t2	L
250	29	362	50	90	55	35	500
300	33	412	51	95	55	40	500
400	47	512	51	110	65	45	500
500	65	622	56	125	75	50	500

※300, 400, 500サイズは縞模様(スベリ止め)有

# KT側溝 3種 消音型 (縦断用) T-25

熊本不二コンクリート工業株式会社

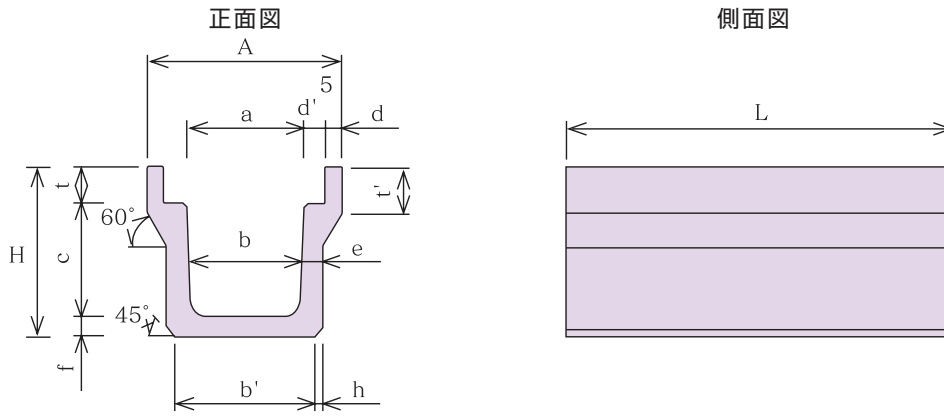

寸法表 (車道用)

呼び名	参考重量(kg)		寸法 (単位mm)												
	L=1000	L=2000	a	c	A	H	d	d'	b	e	h	b'	f	t	t'
300A	210	420	300	300	520	465	50	55	280	70	30	360	70	95	140
400A	259	519	400	400	630	580	55	55	370	70	40	430	70	110	140
500A	352	704	500	500	750	705	60	60	460	80	40	540	80	125	155

# KT側溝 3種蓋 消音型 T-25

kumafuji

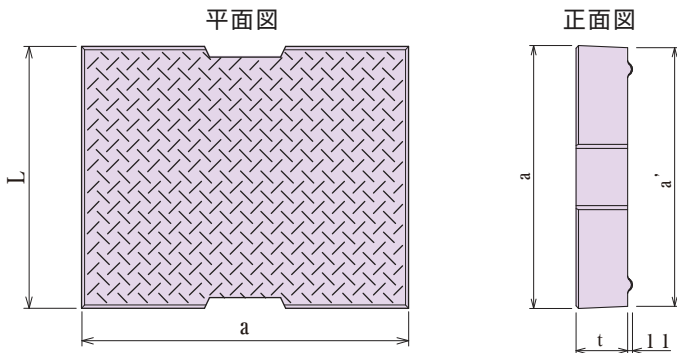

寸法表 (車道用)

呼び名	参考重量(kg)	寸法 (mm)			
		a	a'	t	L
300	45	412	402	92.5	498
400	65	512	502	107.5	498
500	91	622	612	122.5	498

## 集水蓋

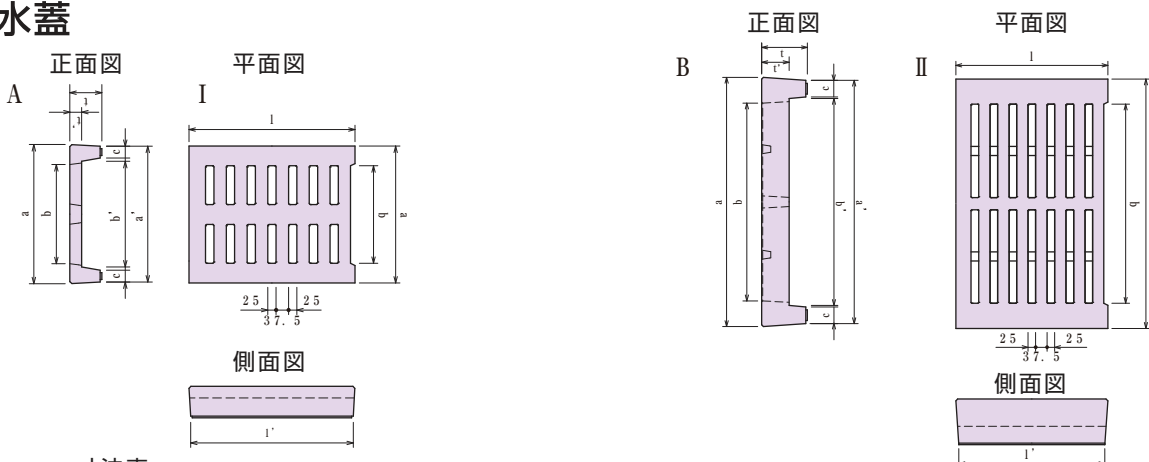

寸法表

基本用途		KT側溝3種											
型式 名称	参考重量(kg)	寸法 (mm)											
		断面	平面	a	a'	b	b'	c	t	t'	l	l'	
P C 型	PC-250(車)	23	A	I	362	352	230	240	50	90	50	500	-
	PC-300(車)	25	A	I	412	402	270	280	50	95	50	500	-
	PC-400(車)	33	A	I	512	502	370	380	50	110	55	500	-
	PC-500(車)	43	B	II	622	612	220×2	230×2	50	125	60	500	-

※PC-250は手掛りなし

# 道路側溝 3種 消音型 (縦断用) T-25 (株) 熊本不二コンクリート工業株式会社

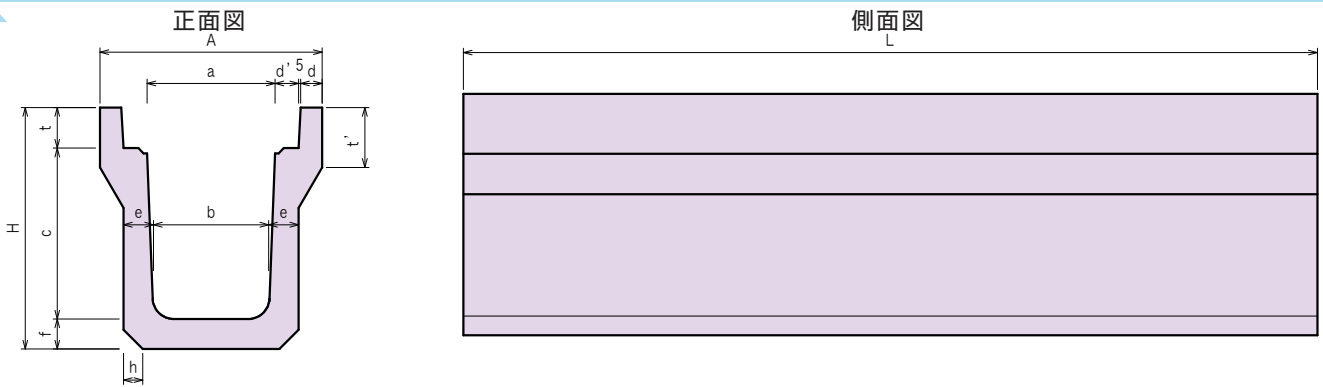

寸法表

種類	呼び名	参考重量 (kg)		寸法 (mm)											
		L=1000	L=2000	A	H	a	b	c	d	d'	e	f	h	t	t'
3種	250	166	332	460	405	250	230	250	45	55	65	65	40	90	120
	300B	235	470	520	565	300	270	400	50	55	70	70	45	95	140
	300C	290	580	520	675	300	260	500	50	55	80	80	50	95	140
	400B	316	632	630	690	400	360	500	55	55	80	80	45	110	140
	500B	424	849	750	815	500	450	600	60	60	90	90	40	125	175

# 道路側溝 3種蓋 消音型 T-25

kumafuji

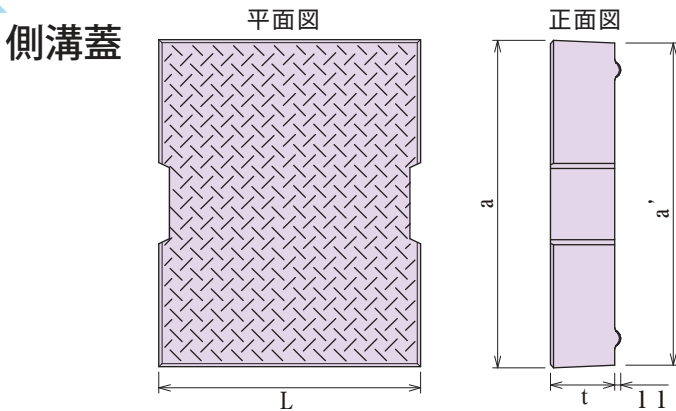

寸法表

種類	呼び名	参考重量 (kg)	寸法 (mm)			
			a	a'	t	L
3種	250	37	362	352	87.5	498
	300	45	412	402	92.5	498
	400	65	512	502	107.5	498
	500	91	622	612	122.5	498

## 集水蓋

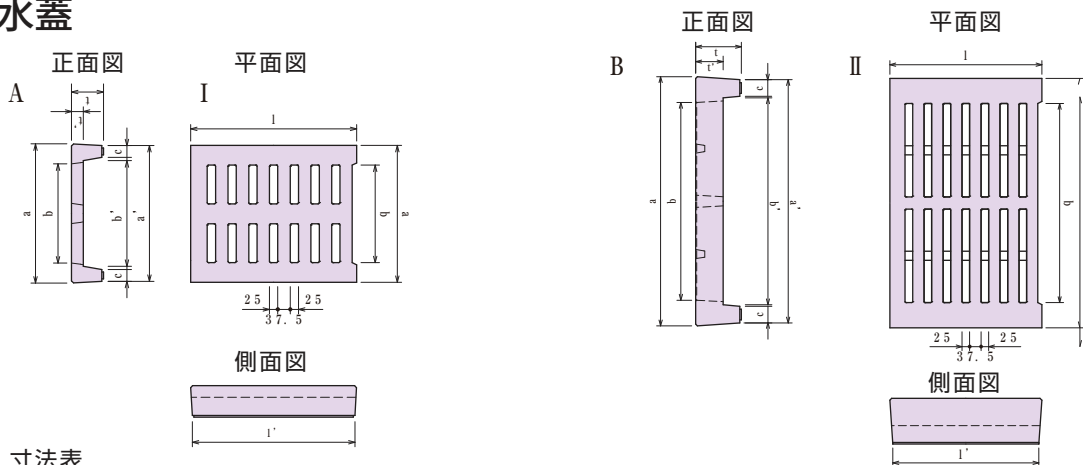

寸法表

基本用途		道路側溝3種											
寸法表 名称	参考重量 (kg)	寸法 (mm)											
		断面	平面	a	a'	b	b'	c	t	t'	l	l'	
PCC型	PC-250(車)	23	A	I	362	352	230	240	50	90	50	500	-
	PC-300(車)	25	A	I	412	402	270	280	50	95	50	500	-
	PC-400(車)	33	A	I	512	502	370	380	50	110	55	500	-
	PC-500(車)	43	B	II	622	612	220×2	230×2	50	125	60	500	-

※PC-250は手掛りなし

# NFC側溝 T-25

側溝用

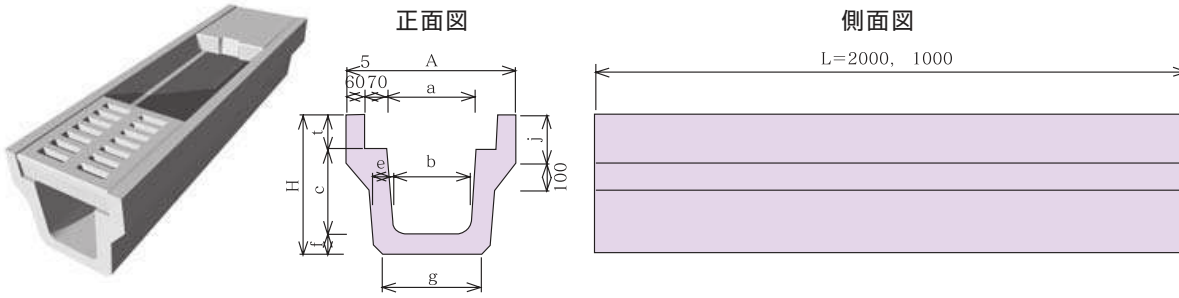

寸法表 単位(mm)

呼び名	参考重量(kg)		寸法									
	L=1000	L=2000	A	H	a	b	c	e	f	g	j	t
300×300	237	474	570	490	300	260	300	70	70	335	170	120
300×400	269	538	570	590	300	260	400	70	70	335	170	120
300×500	300	602	570	690	300	260	500	70	70	335	170	120
400×400	288	576	670	600	400	360	400	70	70	436	180	130
400×500 <sup>㊦</sup>	319	638	670	700	400	360	500	70	70	436	180	130
500×500	384	768	770	730	500	440	500	80	80	515	220	150
600×600	487	975	870	840	600	540	600	90	90	616	220	150

# NFC側溝蓋 T-25

側溝蓋

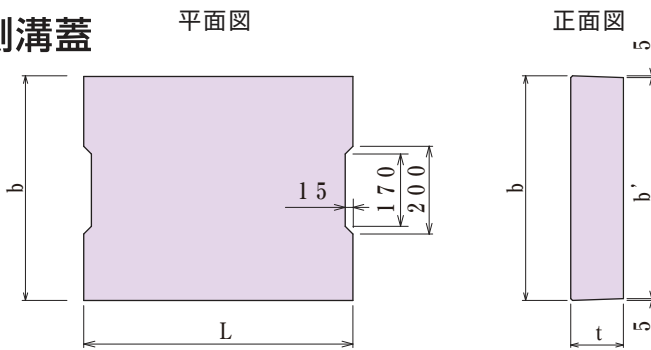

寸法表

呼び名	参考重量(kg)	寸法 (mm)			
		b	b'	t	L
300	62	440	430	120	500
400	83	540	530	130	500
500	114	640	630	150	500
600	132	740	730	150	500

集水蓋 (縦断用)

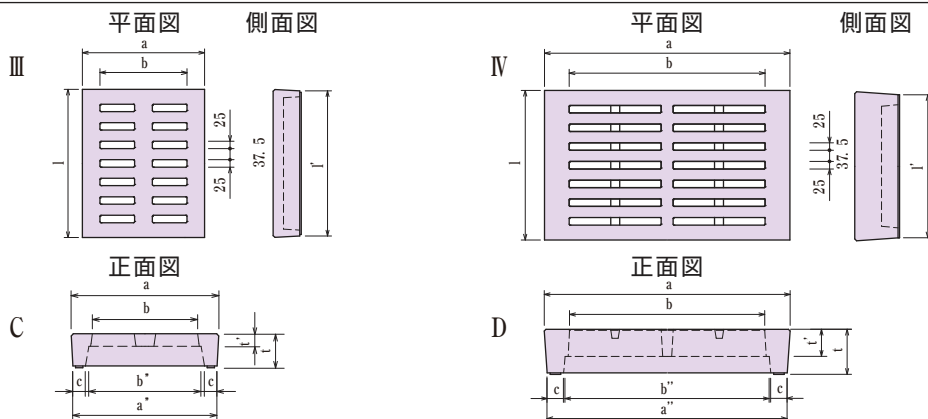

寸法表

基本用途		NFC側溝											
型式名称	参考重量(kg)	寸法 (mm)											
		断面	平面	a	a'	b	b'	c	t	t'	l	l'	
2型	2型300	38	C	Ⅲ	440	430	270	280	65	120	60	500	480
	2型400	48	C	Ⅲ	540	530	370	380	65	130	65	500	480
	2型500	62	D	Ⅳ	640	630	215×2	225×2	65	150	75	500	480
	2型600	70	D	Ⅳ	740	730	265×2	275×2	65	150	75	500	480

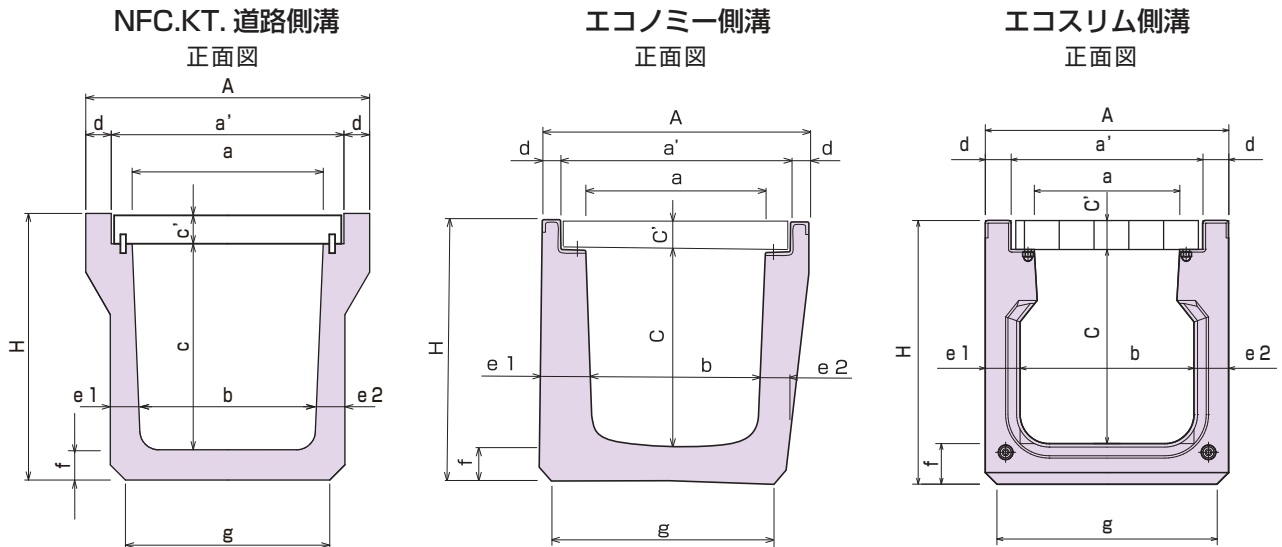

寸法表

呼び名	参考重量 (kg)	寸法 (mm)												
		a	a'	A	b	c	c'	d	e <sub>1</sub>	e <sub>2</sub>	f	g	H	L
NFC 300×300	279 (558)	300	410	570	260	365	55	80	70	70	70	335	490	1000 (2000)
NFC 300×400	310	307	410	570	260	465	55	80	70	70	70	335	590	1000
NFC 300×500	339	305	410	570	260	565	55	80	70	70	70	335	690	1000
NFC 400×400	331	407	510	670	360	465	65	80	70	70	70	436	600	1000
NFC 400×500 <sup>Ⓜ</sup>	361	405	510	670	360	565	65	80	70	70	70	436	700	1000
NFC 500×500	424	505	610	770	440	575	75	80	80	80	80	515	730	1000
NFC 600×600	537	600	710	870	540	660	90	80	100	100	90	674	850	1000
道路側溝3種 250×250	188 (376)	250	360	460	230	290	50	50	65	65	65	280	405	1000 (2000)
道路側溝3種 300×400	246	303	410	520	270	440	55	55	70	70	70	320	565	1000
道路側溝3種 300×500	376	303	410	520	260	540	55	55	100	100	100	320	695	1000
道路側溝3種 400×500	343	404	510	630	360	545	65	60	80	80	80	430	690	1000
道路側溝3種 500×600	450	505	610	750	450	650	75	70	90	90	90	550	815	1000
KT側溝3種 300×300	220 (440)	303	410	520	280	340	55	50	70	70	70	360	465	1000 (2000)
KT側溝3種 400×400	270	403	510	630	370	445	65	55	70	70	70	430	580	1000
KT側溝3種 500×500	364	503	610	750	460	550	75	70	80	80	80	540	705	1000
エコノミー側溝 250×250	152	248	330	392	230	280	50	31	81	51	55	318	385	1000
エコノミー側溝 300×300	178	298	380	442	276	330	50	31	83	51	55	366	435	1000
エコノミー側溝 300×400	221	298	380	442	268	430	50	31	87	56	60	368	540	1000
エコノミー側溝 400×400	492	402	452	542	368	435	55	45	87	60	65	472	555	2000
エコスリム 300×300	189 (378)	250	330	420	300	335	50	45	60	60	70	380	455	1000 (2000)
エコスリム 400×400	265 (527)	350	430	530	400	435	60	50	65	65	80	490	575	1000 (2000)

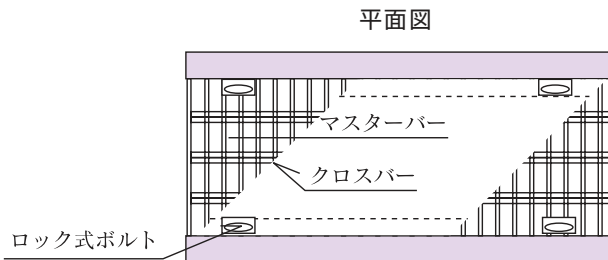

ボルト部詳細図

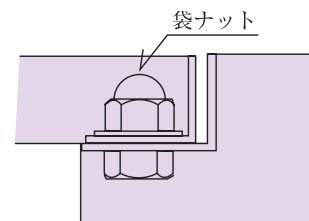

グレーチング寸法表

単位(mm)

	重量(kg)	幅	長さ	高さ
250	23	350	995	50
300	29	400	995	60
400	41	500	995	70
500	63	600	995	80
600	71	700	995	95

## ●道路側溝 種250柵 T-25 縦断用 (受)

平面図

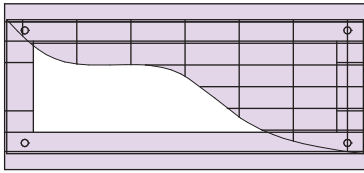

側面図

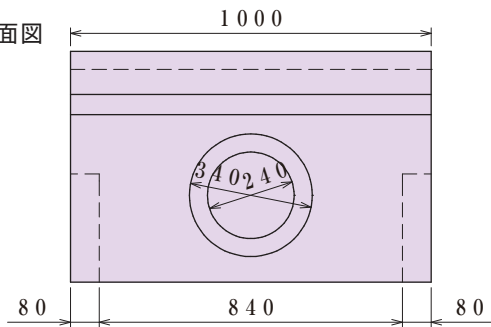

正面図

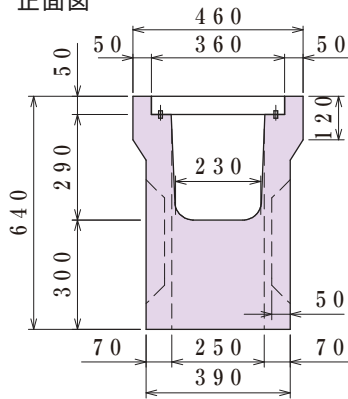

## ●道路側溝集水柵 T-25

参考重量：386kg

平面図

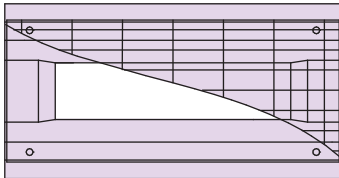

側面図

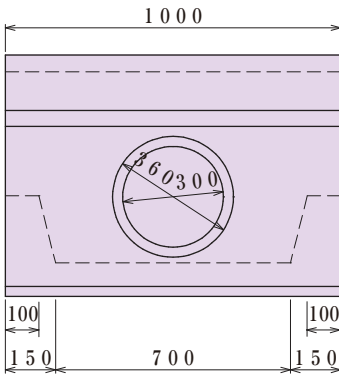

正面図

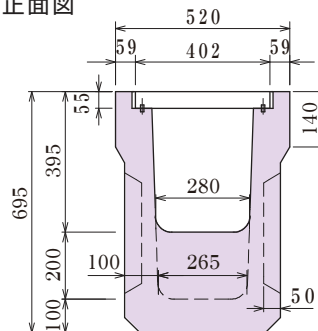

ボルト部詳細図

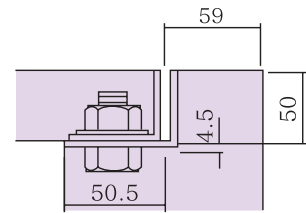

## ●カーブ (3種300Aタイプ) T-25

グレーチングタイプ (受)

平面図

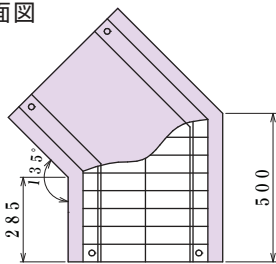

正面図

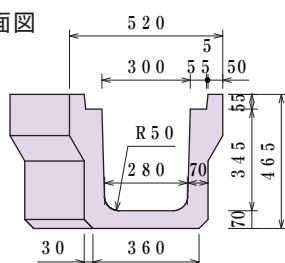

コンクリート蓋タイプ

平面図

重量：163kg

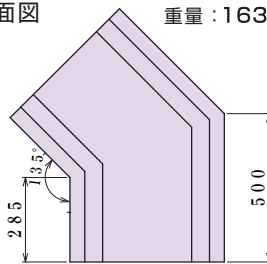

正面図

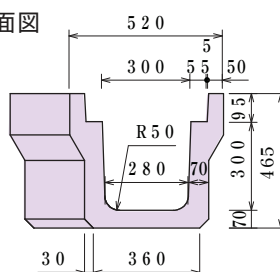

コンクリート蓋

平面図

重量：76kg

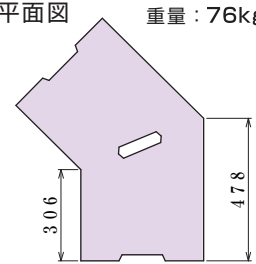

正面図

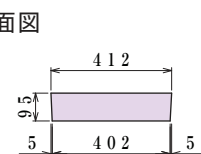



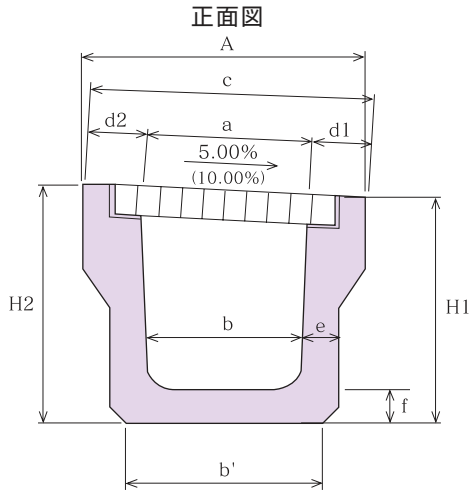

寸法表

呼び名	参考重量	A	H1	H2	a	b	b'	c	d1	d2	e	f
300	5%	230	520	474	500	304	280	360	521	109	108	70
	10%	235	520	474	526	306	280	360	523	109	108	70
400	5%	280	630	587	619	405	370	430	631	113	113	70
	10%	290	630	587	650	407	370	430	633	114	112	70
500	5%	385	750	723	761	506	460	540	751	123	122	80
	10%	395	750	723	798	510	460	540	754	123	121	80

## チェッカード サイレント仕様 (受)

### ●製品規格

平面図

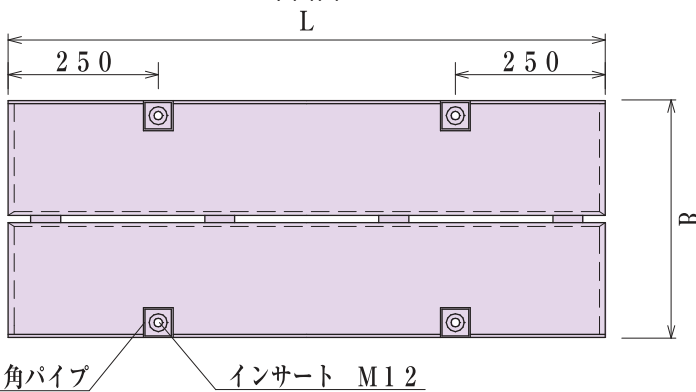

正面図

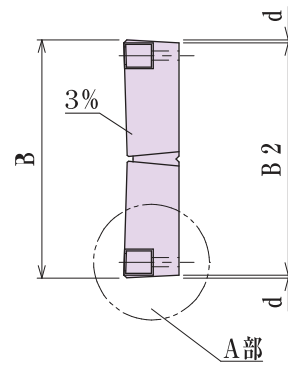

KS側溝型側面図

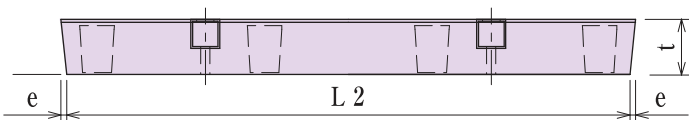

道路側溝型側面図



梁部詳細図

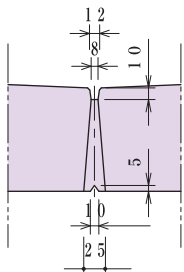

A部詳細図

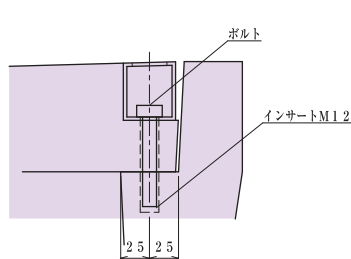

寸法表

(寸法:mm 重量:kg)

サイズ	参考重量	B	B2	d	t	e	L	L2
KS側溝 1型用	300	84	395	385	5	95	10	995
	400	126	495	485	5	110	10	995
	500	172	600	580	10	125	10	995
	600	224	700	600	10	140	10	995
KT側溝 3種兼用 (道路側溝 3種用)	250	74	362	352	5	90	-	995
	300	90	412	402	5	95	-	995
	400	130	512	502	5	110	-	995
	500	182	622	612	5	125	-	995

他のサイズについても対応できます。担当営業までお問合せ下さい。  
※落ち蓋式もあります

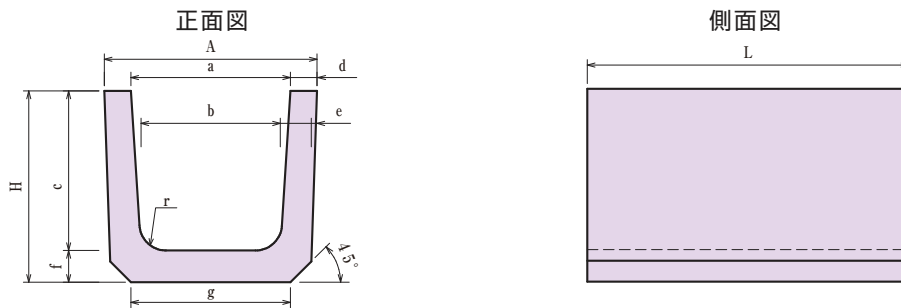

寸法表

呼び名	製品重量 (kg)	寸法 (mm)										
		a	b	c	A	H	d	e	f	g	r	L
150	25(42)	150	140	150	210	185	30	35	35	160	30	600(1,000)
180	33(54)	180	170	180	250	220	35	40	40	190	50	600(1,000)
240	56(93)(186)	240	220	240	330	290	45	50	50	240	50	600(1,000)(2,000)
300A	71	300	260	240	400	300	50	60	60	300	50	600
300B	81(133)(266)	300	260	300	400	360	50	60	60	300	50	600(1,000)(2,000)
300C	93(155)	300	260	360	400	425	50	60	65	300	50	600(1,000)
360A	91	360	310	300	460	365	50	65	65	360	50	600
360B	101(168)(336)	360	310	360	460	425	50	65	65	360	50	600(1,000)(2,000)
450	136(226)(452)	450	400	450	560	520	55	70	70	430	70	600(1,000)(2,000)
600	210(350)(700)	600	540	600	740	680	70	80	80	600	70	600(1,000)(2,000)

注：L=1000,L=2000は目地付

## 鉄筋コンクリートU形1種蓋・2種蓋

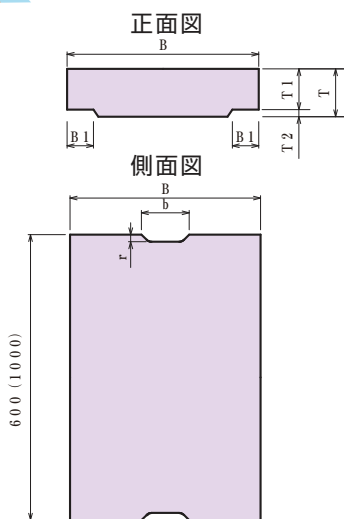

寸法表

種別	呼び名	重量 (kg)	寸法 (mm)						
			B	B <sub>1</sub>	T	T <sub>1</sub>	T <sub>2</sub>	r	b
1種	150	8	210	35	35	30	5	15	75
	180	14(23)	250	40	40	35	5	15	75
	240	21(35)	330	50	45	40	5	15	90
	300	37(62)	400	55	60	50	10	15	100
	360	40	460	55	65	55	10	18	120
	450	54	560	60	70	60	10	18	120
2種	600	77	740	75	75	65	10	18	150
	150	26	210	35	90	80	10	15	75
	180	31	250	40	90	80	10	15	75
	240	45(75)	330	50	100	85	15	15	90
	300	55(92)	400	55	100	85	15	15	100
	360	64	460	55	100	85	15	18	120
種	450	94	560	60	120	100	20	18	120
	600	157	740	75	150	130	20	18	150

※水抜き用切欠きは省くことができます。

## U形用集水蓋 (T-4)

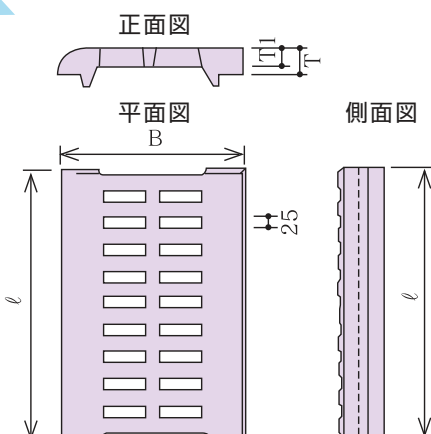

- ・路側にオープン（蓋無）のU字溝がある幅員のせまい道路も最適
- ・車道側にR面を向ける事によりスムーズな乗入れが可能（タイヤの損傷も防ぎます）
- ・底面にゴムクッションを装着、消音タイプです

寸法表

呼び名	重量 (kg)	寸法 (mm)			
		B	T	T <sub>1</sub>	φ
240	18	330	40	30	600
300	24	400	50	40	600

## 標準型

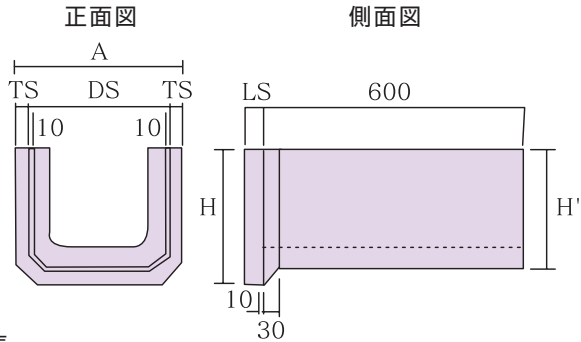

## 滑止付型

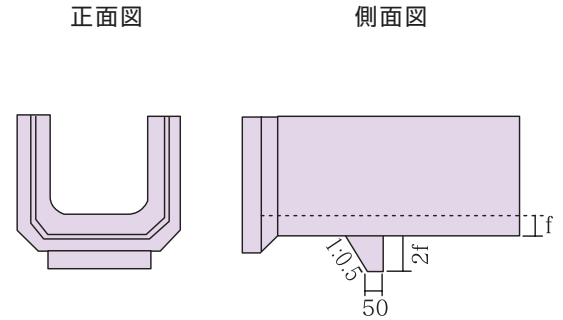

寸法表

名称	寸法	参考重量(Kg)		ソケット寸法(mm)					
		標準	滑止付	内幅	厚さ	深さ	A	H	H'
		W <sub>1</sub>	W <sub>2</sub>	DS	TS	LS			
DV PU240	240×240×600	60	64	350	25	50	400	315	290
DV PU300	300×300×600	85	92	420	30	50	480	390	360

## 標準型

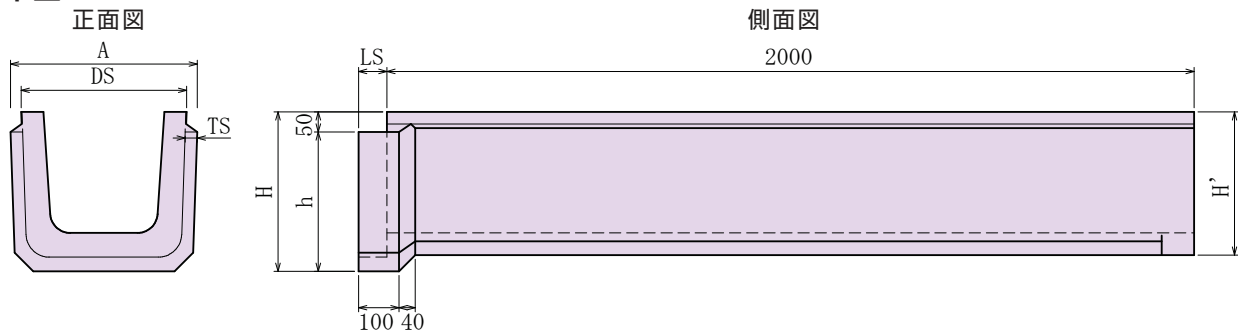

寸法表

名称	寸法	参考重量(Kg)	ソケット寸法(mm)						
		標準	内幅	厚さ	深さ	A	H	H'	h
			DS	TS	LS				
DV PU240	240×240×2000	195	350	30	70	404	330	290	280
DV PU300	300×300×2000	254	410	30	70	462	395	355	345

# 横断側溝 (排水性舗装対応可) T-25

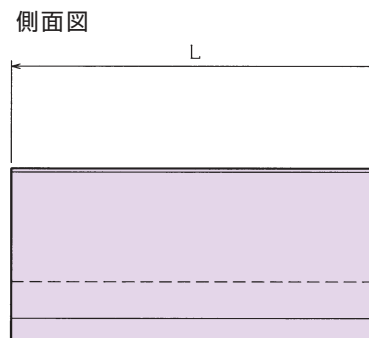
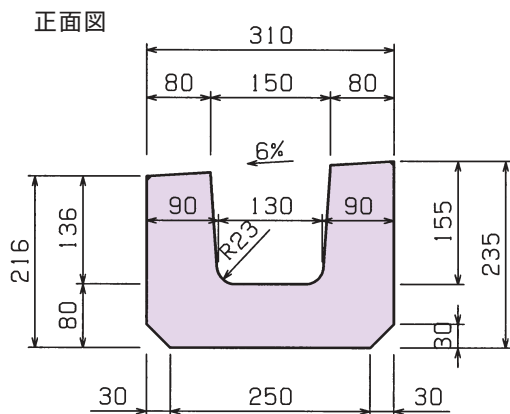

寸法表

呼び名	参考重量 (kg)	L (mm)
150	117	1000
	234	2000
	351	3000
	469	4000
	586	5000
	703	6000

側溝用

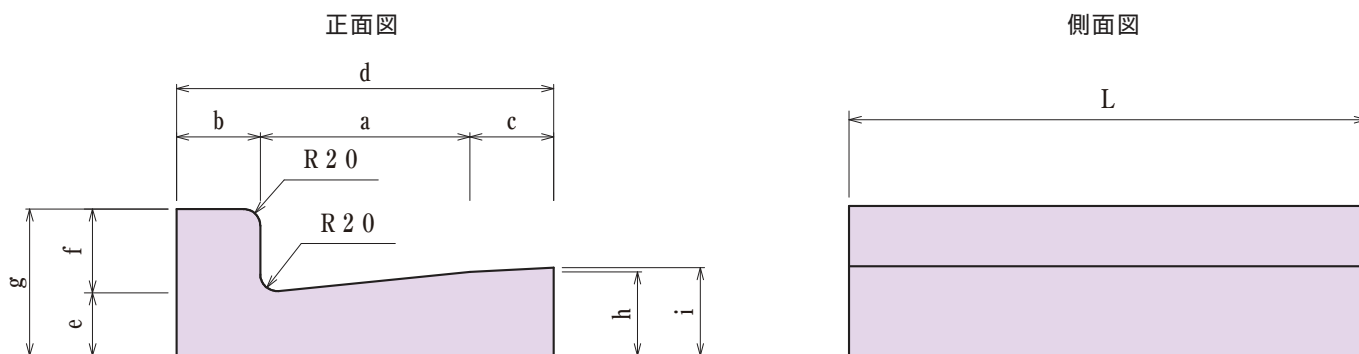

寸法表

呼び名	参考重量 (Kg)	寸法(mm)										
		a	b	c	d	e	f	g	h	i	L	
鉄筋コンクリートL形	1 - 250A	47(78)	250	100	-	350	55	100	155	80	-	600(1000)
	1 - 250B	59	250	100	100	450	55	100	155	80	85	600
	1 - 300	65	300	100	100	500	55	100	155	85	90	600
	1 - 350	72	350	100	100	550	55	100	155	90	95	600

寸法表 (乗入)

呼び名	参考重量 (Kg)	寸法(mm)										
		a	b	c	d	e	f	g	h	i	L	
鉄筋コンクリートL形	250A	40	250	100	-	350	55	50	105	80	-	600
	250B	52	250	100	100	450	55	50	105	80	85	600
	300	58	300	100	100	500	55	50	105	85	90	600
	350 <sup>受</sup>	65	350	100	100	550	55	50	105	90	95	600

PL3型<sup>受</sup>

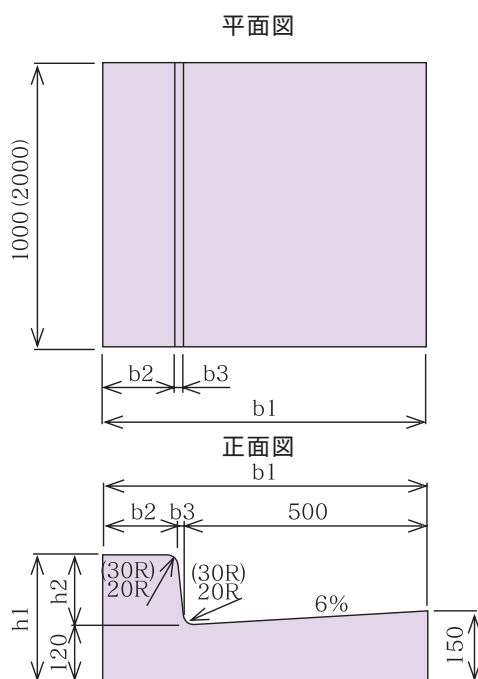

寸法表

単位(mm)

サイズ	1個当たり重量(kg)		b1	b2	b3	h1	h2
	L=600	L=2000					
PL3-H150	166	553	665	150	15	270	150
PL3-H200	194	647	700	180	20	320	200

※PL3-H150,H200にはL=2000もございます。

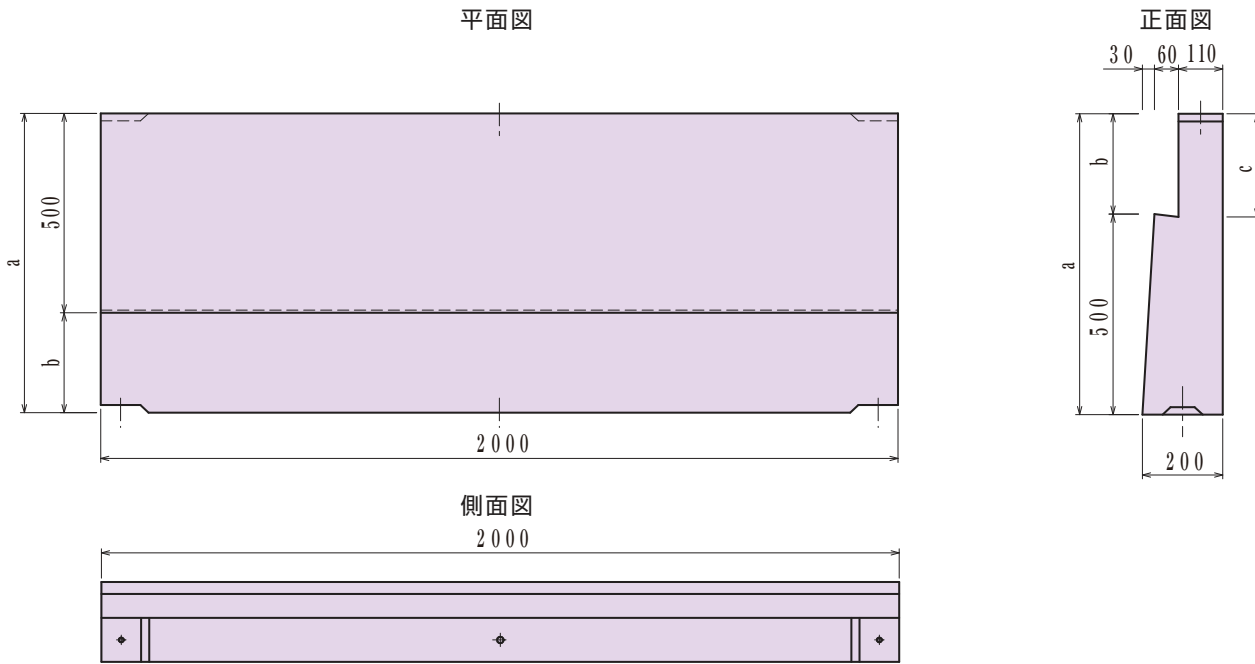

寸法表

呼び名	参考重量(kg)	a	b	c
Aタイプ	568	715	215	222
Bタイプ	586	750	250	257
Cタイプ	590	755	255	262

※H=150も対応可能です。

## V型・皿型側溝

kumafuji

### ●V型側溝500 参考重量 43kg

正面図

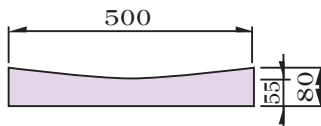

平面図

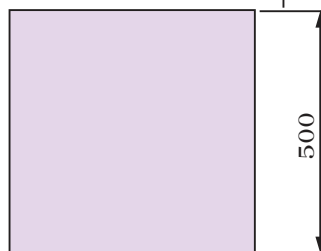

### ●皿型側溝

正面図

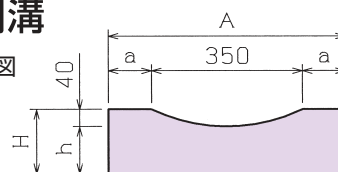

平面図

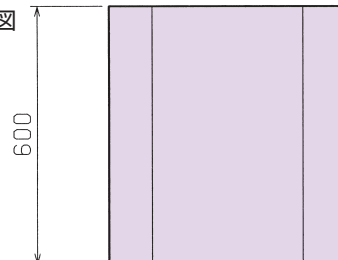

寸法表

呼び名	参考重量(kg)	H	h	A	a
110	58	110	70	450	50
120	72	120	80	550	100
150	96	150	110	550	100

# KS側溝 I型 T-25 (縦断用) 消音型

熊本不二コンクリート工業株式会社

側溝用

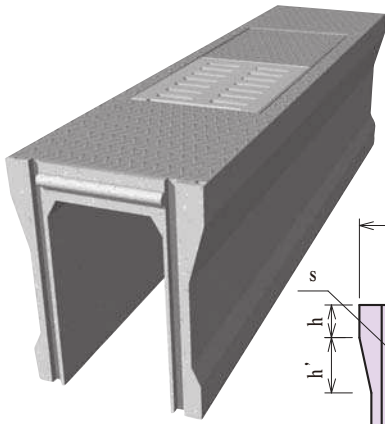

※ボルトロック製作可能  
※横断用製作可能

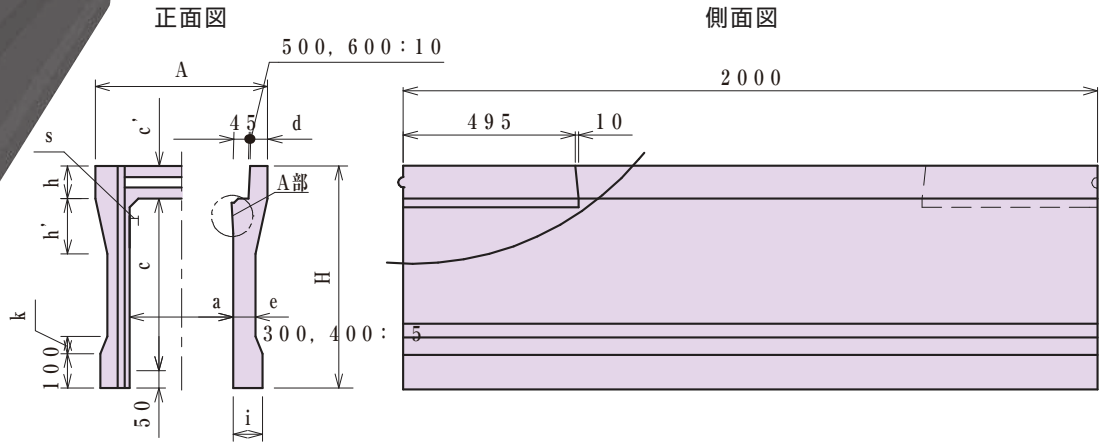

A部詳細図

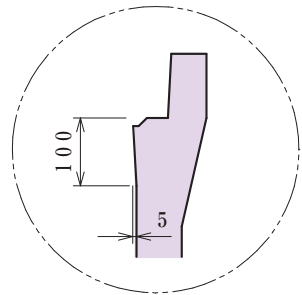

寸法表

呼び名	参考重量 (kg)	寸法 (mm)												呼び名	
		A	H	a	c	c'	d	e	h	h'	s	i	k		
300 × 300	356	500	445	300	95	50	65	95	160	25	85	50	50	300 × 300	
× 400	408		545												400
× 500	460		645												500
× 600	558		745												600
× 700	619		845												700
× 800	745		945												800
× 900	817		1,045												900
× 1,000	977		1,145												1,000
× 1,100	1,056		1,245												1,100
× 1,200	1,135		1,345												1,200
400 × 400	470	610	560	400	110	55	60	110	160	40	90	60	400 × 400		
× 500	545		660											500	
× 600	601		760											600	
× 700	713		860											700	
× 800	779		960											800	
× 900	917		1,060											900	
× 1,000	993		1,160											1,000	
× 1,100	1,167		1,260											1,100	
× 1,200	1,246		1,360											1,200	
500 × 500	658		720											675	500
× 600	724	775		600											
× 700	790	875		700											
× 800	856	975		800											
× 900	1,031	1,075		900											
× 1,000	1,111	1,175		1,000											
× 1,100	1,191	1,275		1,100											
× 1,200	1,373	1,375		1,200											
× 1,300	1,462	1,475		1,300											
× 1,400	1,551	1,575		1,400											
600 × 600	832	830	790	600	140	60	75	140	180	55	100	80	600 × 600		
× 700	902		890											700	
× 800	972		990											800	
× 900	1,043		1,090											900	
× 1,000	1,236		1,190											1,000	
× 1,100	1,321		1,290											1,100	
× 1,200	1,406		1,390											1,200	
× 1,300	1,602		1,490											1,300	
× 1,400	1,696		1,590											1,400	
× 1,500	1,790		1,690											1,500	

# KS側溝 大型 T-25 消音型

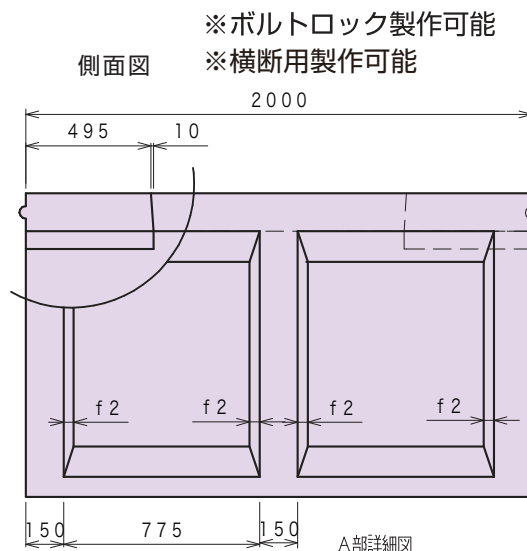
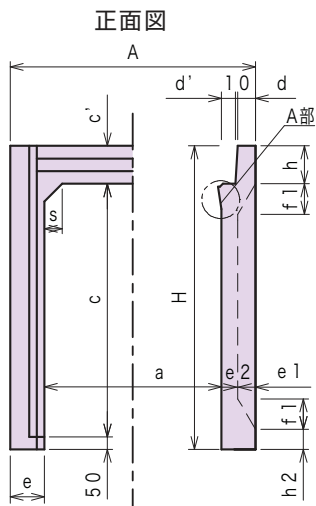
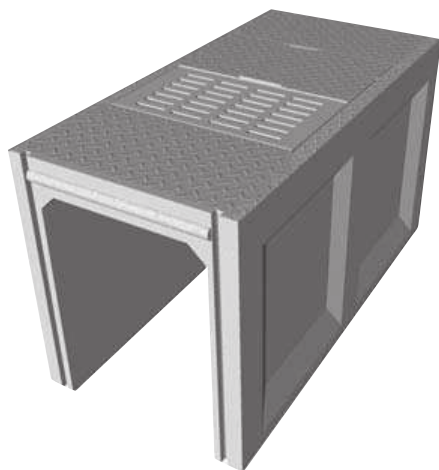

※ボルトロック製作可能  
※横断用製作可能

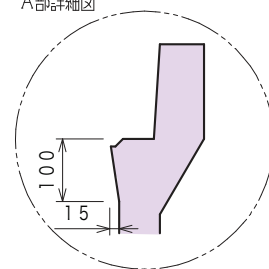

寸法表

呼び名	参考重量 (kg)	寸法 (mm)															呼び名		
		A	H	a	c	c'	d	d'	e	e1	e2	f1	f2	h1	h2	s			
700 × 700	1,070	970	900	700	700	150	70	55	135	70	65	120	40	150	80	70	700 × 700		
	1,147		1,000															800	700 × 800
	1,225		1,100															900	700 × 900
	1,303		1,200															1,000	700 × 1,000
	1,380		1,300															1,100	700 × 1,100
	1,458		1,400															1,200	700 × 1,200
	1,540		1,500															1,300	700 × 1,300
	1,618		1,600															1,400	700 × 1,400
	1,696		1,700															1,500	700 × 1,500
	1,773		1,800															1,600	700 × 1,600
1,851	1,900	1,700	700 × 1,700																
800 × 800	1,262	1,080	1,010	800	800	160	75	55	140	70	70	120	40	160	80	80	800 × 800		
	1,344		1,110															900	800 × 900
	1,427		1,210															1,000	800 × 1,000
	1,509		1,310															1,100	800 × 1,100
	1,591		1,410															1,200	800 × 1,200
	1,674		1,510															1,300	800 × 1,300
	1,761		1,610															1,400	800 × 1,400
	1,843		1,710															1,500	800 × 1,500
	1,925		1,810															1,600	800 × 1,600
	2,008		1,910															1,700	800 × 1,700
2,090	2,010	1,800	800 × 1,800																
2,172	2,110	1,900	800 × 1,900																
900 × 900	1,466	1,190	1,120	900	900	170	75	60	145	70	75	120	40	170	80	90	900 × 900		
	1,533		1,220															1,000	900 × 1,000
	1,640		1,320															1,100	900 × 1,100
	1,727		1,420															1,200	900 × 1,200
	1,814		1,520															1,300	900 × 1,300
	1,901		1,620															1,400	900 × 1,400
	1,993		1,720															1,500	900 × 1,500
	2,080		1,820															1,600	900 × 1,600
	2,167		1,920															1,700	900 × 1,700
	2,254		2,020															1,800	900 × 1,800
2,341	2,120	1,900	900 × 1,900																
1,000 × 1,000	1,688	1,300	1,230	1,000	1,000	180	80	60	150	70	80	120	40	180	80	100	1,000 × 1,000		
	1,780		1,330															1,100	1,000 × 1,100
	1,872		1,430															1,200	1,000 × 1,200
	1,963		1,530															1,300	1,000 × 1,300
	2,055		1,630															1,400	1,000 × 1,400
	2,147		1,730															1,500	1,000 × 1,500
	2,244		1,830															1,600	1,000 × 1,600
	2,335		1,930															1,700	1,000 × 1,700
	2,427		2,030															1,800	1,000 × 1,800
	2,519		2,130															1,900	1,000 × 1,900
2,610	2,230	2,000	1,000 × 2,000																

※横断対応も可能です(別設計)ご相談下さい

(車道用) 平面図

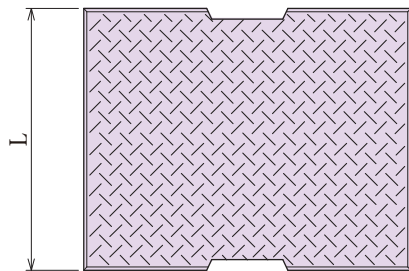

正面図

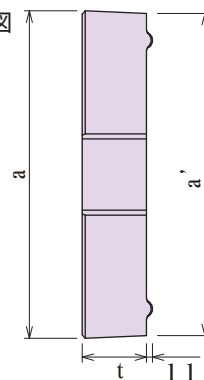

寸法表 (車道用)

呼び名	参考重量 (kg)	寸法 (mm)				
		a	a'	t	L	
車道用	300	42	395	385	92.5	498
	400	63	495	485	107.5	498
	500	86	600	580	122.5	498
	600	112	700	680	137.5	498
	700	137	820	800	147.5	498
	800	165	920	900	157.5	498
	900	196	1,030	1,010	167.5	498
	1,000	228	1,130	1,110	177.5	498

(軽荷重用) 平面図

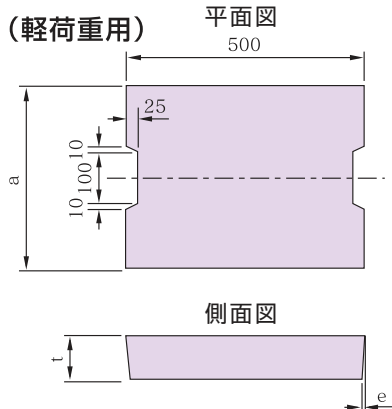

正面図

寸法表 (軽荷物用)

呼び名	参考重量 (kg)	寸法 (mm)						
		a	a'	d'	t	t'	e	
軽荷重用	300	31	395	385	50	95	55	5
	400	45	495	485		110	65	
	500	59	600	580		125	70	
	600	76	700	680	55	140	80	10
	700	89	820	800		150	85	
	800	106	920	900		160	90	
	900	125	1,030	1,010	60	170	95	10
	1,000	144	1,130	1,110		180	100	

(集水蓋) タイプ I

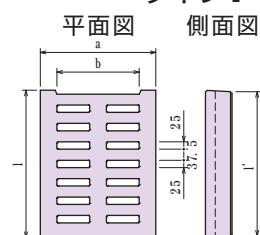

タイプ II

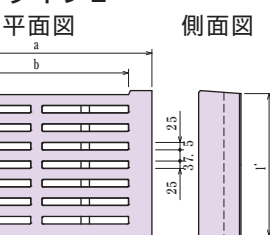

寸法表

基本用途		KS側溝1型											
型式名称	参考重量 (kg)	寸法 (mm)											
		断面	平面	a	a'	b	b'	c	t	t'	l	l'	
1型	1型300	25	A	I	395	385	250	260	50	95	50	500	480
	1型400	33	A	I	495	485	350	360	50	110	60	500	480
	1型500	43	B	II	600	580	205x2	215x2	50	125	65	500	480
	1型600	52	B	II	700	680	255x2	265x2	50	140	70	500	480

正面図 A

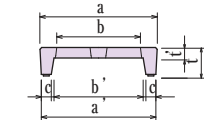

正面図 B

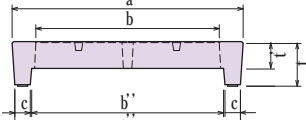

タイプ IV

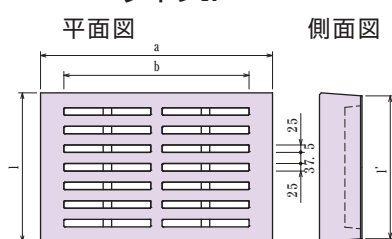

正面図 D

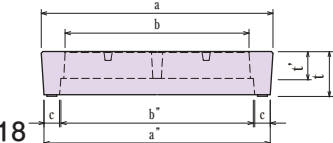

寸法表

基本用途		KS側溝大型											
型式名称	参考重量 (kg)	寸法 (mm)											
		断面	平面	a	a'	b	b'	c	t	t'	l	l'	
大型	大型 700	74	D	IV	820	800	310x2	320x2	50	150	90	500	480
	大型 800	93	D	IV	920	900	360x2	360x2	55	160	90	500	480
	大型 900	111	D	IV	1,030	1,010	420x2	420x2	55	170	100	500	480
	大型1,000	122	D	IV	1,130	1,110	470x2	470x2	55	180	105	500	480



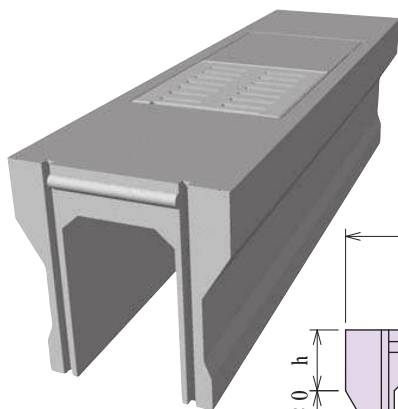

※ボルトロック製作可能  
※横断用製作可能

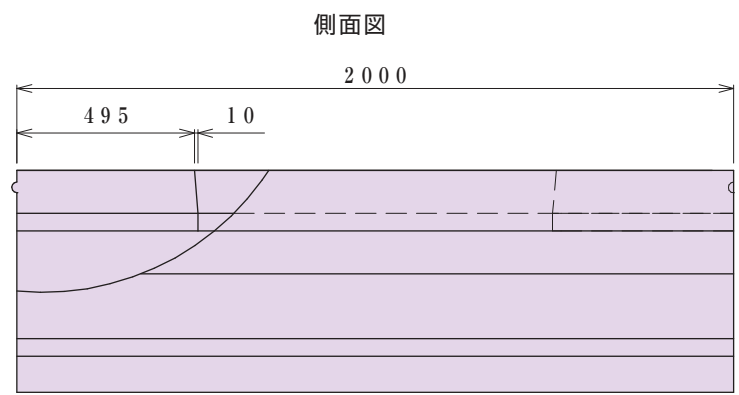
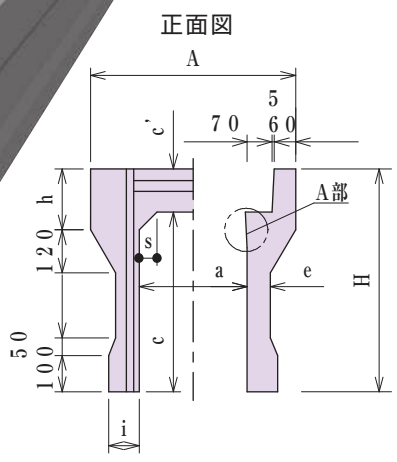

A部詳細図

A部詳細図

溝付き（消音仕様）

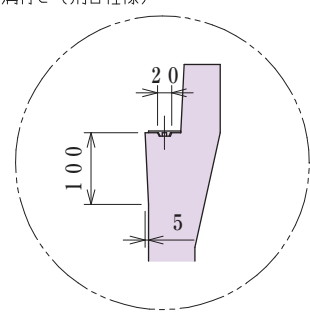
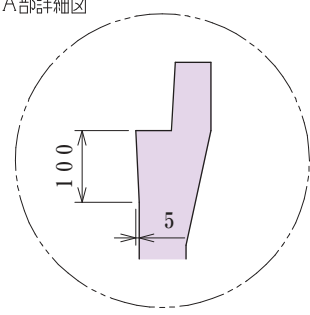

寸法表

呼び名	参考重量 (kg)	寸法 (mm)										呼び名							
		A	H	a	C	C'	e	h	S	i									
300 × 400	545	570	520	300	400	120	65	170	50	85	300 × 400								
	614		620		500						× 500								
	683		720		600						× 600								
	752		820		700						× 700								
	821		920		800						× 800								
	890		1,020		900						× 900								
	959		1,120		1,000						× 1,000								
	1,028		1,220		1,100						× 1,100								
	1,097		1,320		1,200						× 1,200								
	400 × 500		659		670						630	400	500	130	70	170	50	90	400 × 500
			733								730		600						× 600
			806								830		700						× 700
879		930	800	× 800															
952		1,030	900	× 900															
1,026		1,130	1,000	× 1,000															
1,100		1,230	1,100	× 1,100															
1,174		1,330	1,200	× 1,200															
1,248		1,430	1,300	× 1,300															
500 × 600		851	770	750		500	600	150	75	200	70		95						500 × 600
		929		850			700												× 700
		1,006		950			800												× 800
	1,084	1,050		900	× 900														
	1,161	1,150		1,000	× 1,000														
	1,239	1,250		1,100	× 1,100														
	1,317	1,350		1,200	× 1,200														
	1,395	1,450		1,300	× 1,300														
	1,473	1,550		1,400	× 1,400														
	600 × 600	918		870	750		600					600		150	100	200	75	100	600 × 600
		1,008			850							700							× 700
		1,082			950							800							× 800
1,164		1,050	900		× 900														
1,246		1,150	1,000		× 1,000														
1,327		1,250	1,100		× 1,100														
1,409		1,350	1,200		× 1,200														
1,491		1,450	1,300		× 1,300														
1,573		1,550	1,400		× 1,400														
1,655		1,650	1,500		× 1,500														

## 側溝蓋

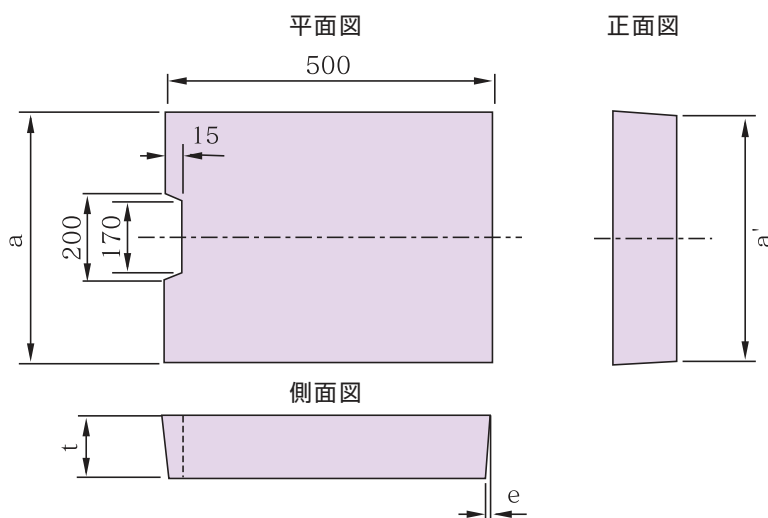

寸法表 単位(mm)

呼び名	参考重量 (kg)	a	a'	t	e
300	62	440	430	120	10
400	83	540	530	130	10
500	114	640	630	150	10
600	132	740	730	150	10

## 集水蓋

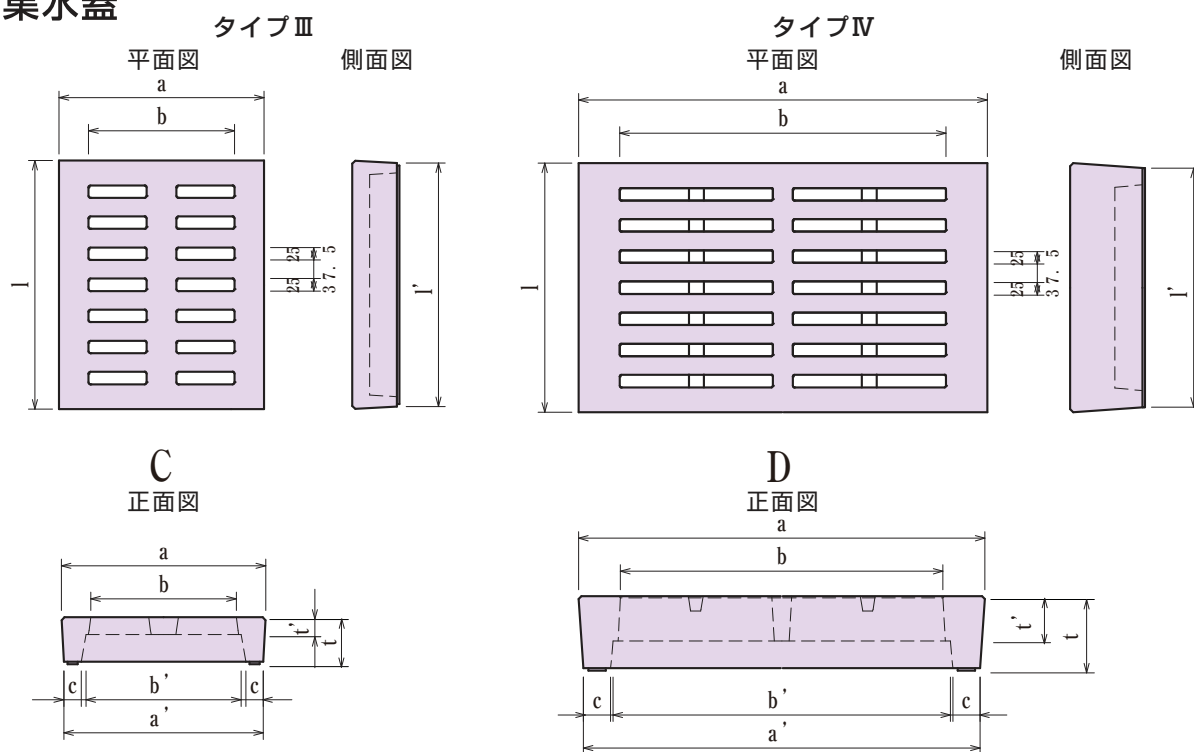

寸法表

基本用途		KS側溝2型、NFC側溝										
型式 名称	参考重量 (kg)	寸法 (mm)										
		断面	平面	a	a'	b	b'	c	t	t'	l	l'
2型	2型300	C	Ⅲ	440	430	270	280	65	120	60	500	480
	2型400	C	Ⅲ	540	530	370	380	65	130	65	500	480
	2型500	D	Ⅳ	640	630	215×2	225×2	65	150	75	500	480
	2型600	D	Ⅳ	740	730	265×2	275×2	65	150	75	500	480

# KS側溝 I型ウォール(縦断用)消音型 (受)

熊本不二コンクリート工業株式会社

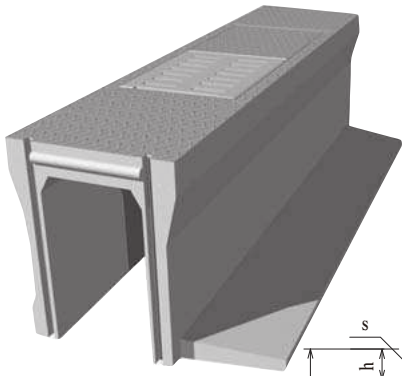

正面図

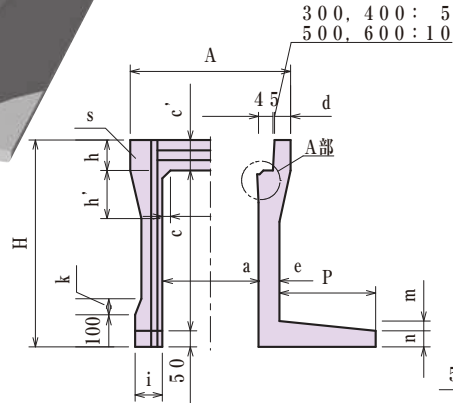

側面図

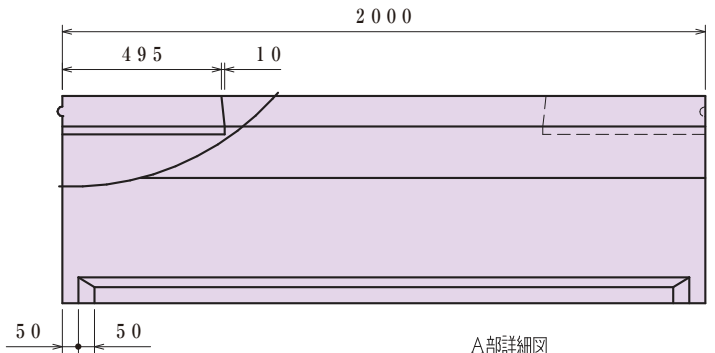

A部詳細図

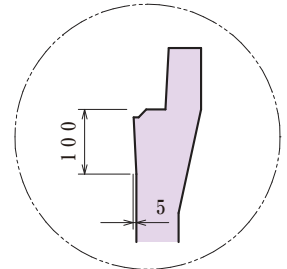

寸法表

呼び名	参考重量 (kg)	寸法 (mm)														呼び名																																																				
		A	H	a	c	c'	d	e	h	h'	s	i	k	p	m		n																																																			
300 × 300	425	500	445	300	300	95	50	65	95	100	85	40	300	30	50	50	300 × 300																																																			
	537		400		400					25								85	50	300	30	50																																														
	589		645		500					150													90	70	400	40	50																																									
	654		745		600					160																		90	70	400	40	50																																				
	752		845		700					170																							90	70	400	40	50																															
	882		945		800					180																												90	70	400	40	50																										
	995		1,045		900					190																																	90	70	400	40	50																					
	1,130		1,145		1,000					200																																						90	70	400	40	50																
	1,210		1,245		1,100					210																																											90	70	400	40	50											
1,290	1,345	1,200	220	90	70	400	40	50	50	1,200 × 1,200																																																										
400 × 400	558	610	560	400	400	110	55	60	110	150	90	50	400	30	70	300	30	50	400 × 400																																																	
	630		660		500					60		90								70	300	30	70																																													
	686		760		600					70														90	70	400	40	70																																								
	845		860		700					80																			90	70	400	40	70																																			
	910		960		800					90																								90	70	400	40	70																														
	1,054		1,060		900					100																													90	70	400	40	70																									
	1,171		1,160		1,000					110																																		90	70	400	40	70																				
	1,340		1,260		1,100					120																																							90	70	400	40	70															
	1,472		1,360		1,200					130																																												90	70	400	40	70										
	738		675		500					70																																																	90	70	400	40	70					
	804		775		600					80																																																						90	70	400	40	70
	907		875		700					90																																																										
973	975	800	100	95	75	400	40	70																																																												
1,155	1,075	900	110						95	75	400	40	70																																																							
1,276	1,175	1,000	120											95	75	400	40	70																																																		
1,356	1,275	1,100	130																95	75	400	40	70																																													
1,543	1,375	1,200	140																					95	75	400	40	70																																								
1,678	1,475	1,300	150																										95	75	400	40	70																																			
1,767	1,575	1,400	160																															95	75	400	40	70																														
738	675	500	70																																				95	75	400	40	70																									
804	775	600	80																																									95	75	400	40	70																				
907	875	700	90																																														95	75	400	40	70															
973	975	800	100																																																			95	75	400	40	70										
1,155	1,075	900	110																																																								95	75	400	40	70					
1,276	1,175	1,000	120	100	75	400	40	70																																																												
1,356	1,275	1,100	130						100	75	400	40	70																																																							
1,543	1,375	1,200	140											100	75	400	40	70																																																		
1,678	1,475	1,300	150																100	75	400	40	70																																													
1,767	1,575	1,400	160																					100	75	400	40	70																																								
911	790	600	75																										100	75	400	40	70																																			
981	890	700	85																															100	75	400	40	70																														
1,088	990	800	95																																				100	75	400	40	70																									
1,159	1,090	900	105																																									100	75	400	40	70																				
1,359	1,190	1,000	115																																														100	75	400	40	70															
1,486	1,290	1,100	125																																																			100	75	400	40	70										
1,570	1,390	1,200	135																																																								100	75	400	40	70					
1,816	1,490	1,300	145	100	75	400	40	70																																																												
1,910	1,590	1,400	155						100	75	400	40	70																																																							
2,004	1,690	1,500	165											100	75	400	40	70																																																		

# KS側溝 大型ウォール 消音型 T-25 受

熊本不二コンクリート工業株式会社

側溝用

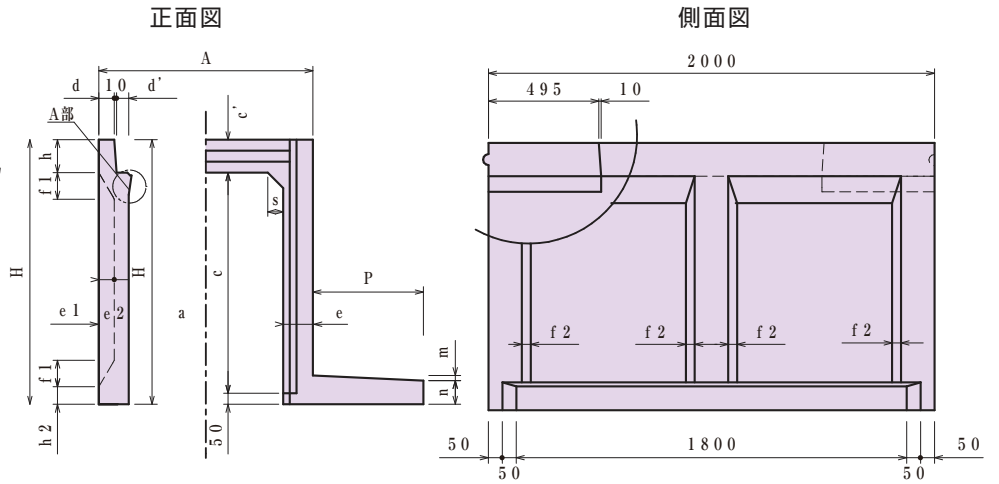
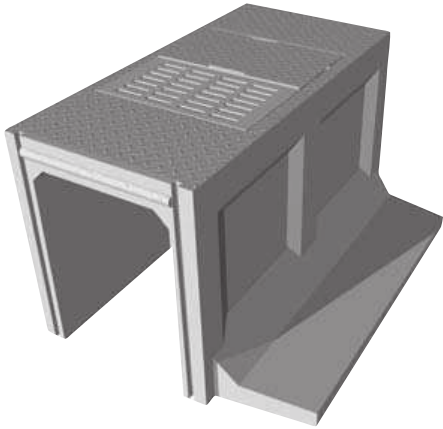

寸法表

呼び名	参考重量 (kg)	寸法 (mm)																呼び名		
		A	H	a	c	c'	d	d'	e	e1	e2	f1	f2	h1	h2	p	n		m	
700 × 700	1,298	970	900	700	150	70	55	135	70	65	120	40	150	80	400	86	14	700 × 700		
	1,375		1,000												800	450	85		15	× 800
	1,486		1,100												900	500	83		17	× 900
	1,591		1,200												1,000	550	80		19	× 1,100
	1,696		1,300												1,100	600	79		21	× 1,200
	1,807		1,400												1,200	700	76		24	× 1,300
	1,931		1,500												1,300	750	74		26	× 1,400
	2,032		1,600												1,400	800	72		28	× 1,500
	2,138		1,700												1,500	850	71		29	× 1,600
	2,243		1,800												1,600	900	69		31	× 1,700
2,348	1,900	1,700	950	67	33	× 1,800														
800 × 800	1,490	1,080	1,010	800	160	75	55	140	70	70	120	40	160	80	400	86	14	800 × 800		
1,605	1,110		900												450	85	15	× 900		
1,715	1,210		1,000												500	83	17	× 1,000		
1,825	1,310		1,100												550	81	19	× 1,100		
1,940	1,410		1,200												600	79	21	× 1,200		
2,065	1,510		1,300												700	76	24	× 1,300		
2,175	1,610		1,400												750	74	26	× 1,400		
2,285	1,710		1,500												800	72	28	× 1,500		
2,395	1,810		1,600												850	71	29	× 1,600		
2,505	1,910		1,700												900	69	31	× 1,700		
2,625	2,010	1,800	950	65	35	× 1,800														
900 × 900	1,727	1,190	1,120	900	170	75	60	145	70	75	120	40	170	80	450	85	15	900 × 900		
1,821	1,220		1,000												500	83	17	× 1,000		
1,956	1,320		1,100												550	81	19	× 1,100		
2,076	1,420		1,200												600	79	21	× 1,200		
2,205	1,520		1,300												700	76	24	× 1,300		
2,315	1,620		1,400												750	74	26	× 1,400		
2,435	1,720		1,500												800	72	28	× 1,500		
2,550	1,820		1,600												850	71	29	× 1,600		
2,664	1,920		1,700												900	69	31	× 1,700		
2,789	2,020		1,800												950	67	33	× 1,800		
2,876	2,120	1,900	1000	65	35	× 1,900														
1,000 × 1,000	1,976	1,300	1,230	1,000	180	80	60	150	70	80	120	40	180	80	500	83	17	1,000 × 1,000		
2,096	1,330		1,100												550	81	19	× 1,100		
2,221	1,430		1,200												600	79	21	× 1,200		
2,354	1,530		1,300												700	76	24	× 1,300		
2,470	1,630		1,400												750	74	26	× 1,400		
2,589	1,730		1,500												800	72	28	× 1,500		
2,714	1,830		1,600												850	71	29	× 1,600		
2,832	1,930		1,700												900	69	31	× 1,700		
2,962	2,030		1,800												950	67	33	× 1,800		
3,054	2,130		1,900												1000	65	35	× 1,900		
3,145	2,230	2,000	1000	65	35	× 2,000														

※横断対応も可能です(別設計)ご相談下さい

# KS側溝Ⅱ型ウォール T-25 受

熊本不二コンクリート工業株式会社

側溝用

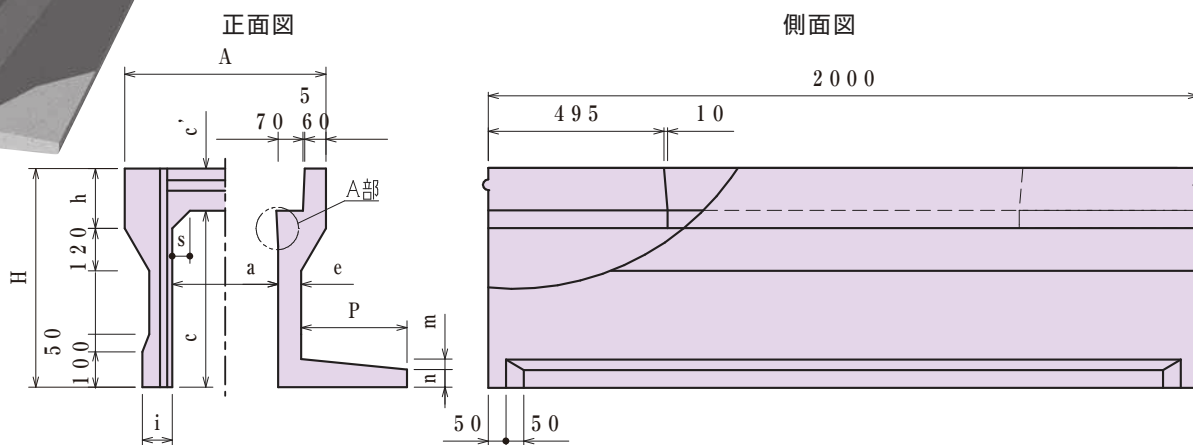
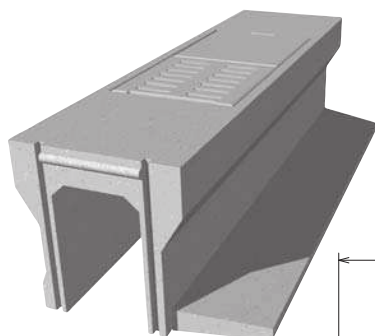

A部詳細図

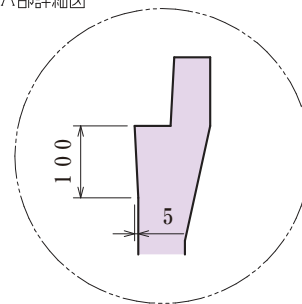

寸法表

呼び名	参考重量 (kg)	寸法 (mm)											呼び名			
		A	H	a	C	C'	e	h	S	i	p	n		m		
300 × 400	595	570	520	300	400	120	65	170	50	85	280	60	20	300 × 400		
× 500	664		620												500	280
× 600	733		720												600	280
× 700	802		820												700	280
× 800	871		920												800	280
× 900	949		1,020												900	330
× 1,000	1,044		1,120												1,000	480
× 1,100	1,113		1,220												1,100	480
× 1,200	1,182		1,320												1,200	480
× 1,300	1,251		1,420												1,300	480
400 × 500	709	670	630	400	500	130	70	170	50	90	285	60	20	400 × 500		
× 600	783		730												600	285
× 700	856		830												700	285
× 800	929		930												800	285
× 900	1,010		1,030												900	335
× 1,000	1,093		1,130												1,000	385
× 1,100	1,176		1,230												1,100	435
× 1,200	1,259		1,330												1,200	485
× 1,300	1,333		1,430												1,300	485
× 1,400	1,416		1,530												1,400	485
500 × 600	913	770	750	500	600	150	75	200	70	95	280	70	30	500 × 600		
× 700	991		850												700	280
× 800	1,079		950												800	330
× 900	1,157		1,050												900	330
× 1,000	1,256		1,150												1,000	430
× 1,100	1,345		1,250												1,100	480
× 1,200	1,428		1,350												1,200	500
× 1,300	1,506		1,450												1,300	500
× 1,400	1,595		1,550												1,400	550
× 1,500	1,684		1,650												1,500	550
600 × 600	991	870	750	600	600	150	100	200	75	100	330	70	30	600 × 600		
× 700	1,081		850												700	330
× 800	1,155		950												800	330
× 900	1,270		1,050												900	480
× 1,000	1,352		1,150												1,000	480
× 1,100	1,427		1,250												1,100	500
× 1,200	1,510		1,350												1,200	500
× 1,300	1,602		1,450												1,300	500
× 1,400	1,695		1,550												1,400	550
× 1,500	1,788		1,650												1,500	600

## ●カセットウォールとは？

独立した底版を、可変勾配側溝にセットして一体化し、土留用に使用します！

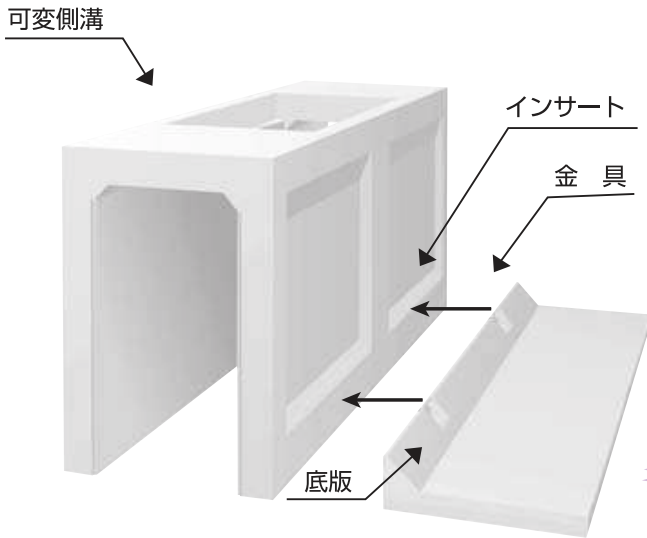

## ●特徴

- ①設計荷重に対し、適切な底版を自由に選択できます。
- ②底版が独立しているため、据付が簡単。

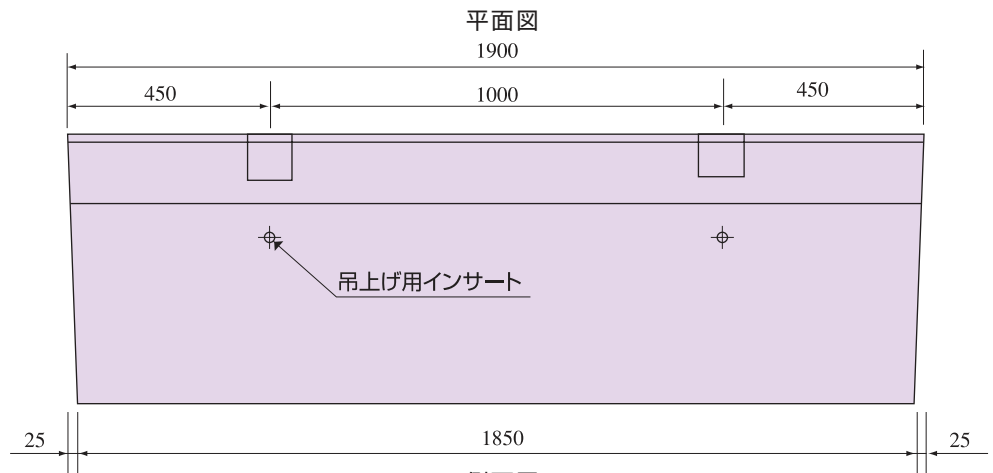
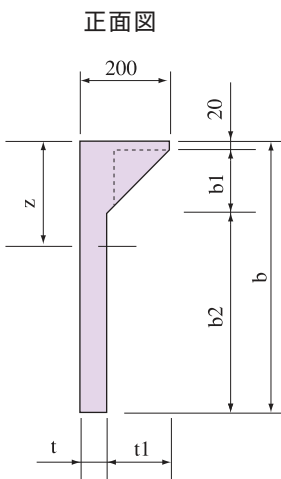
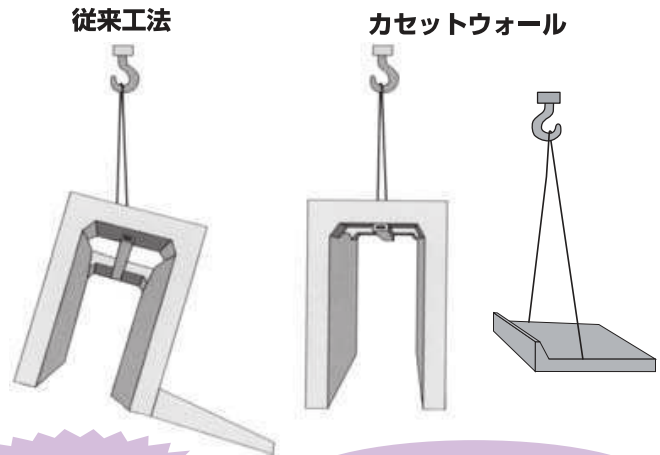

寸法表

呼び名 b	寸法 (mm)						参考重量 (kg)
	b	b1	b2	t	t1	z	
350	350	150	180	60	140	190	156
400	400		230			190	170
450	450		280			190	184
500	500		330			190	197
550	550		380			210	211
600	600	135	430	90	110	230	225
650	650		495			280	311
700	700		545			310	331
750	750		595			330	352
800	800		645			350	372
850	850	100	695	100	100	380	393
900	900		745			400	413
1000	1000		880			460	488
1100	1100		980			510	534
						510	

# KS側溝Ⅱ型スロープ本体

T-25 (受)

熊本不二コンクリート工業株式会社

※ボルトロック製作可能

側溝用

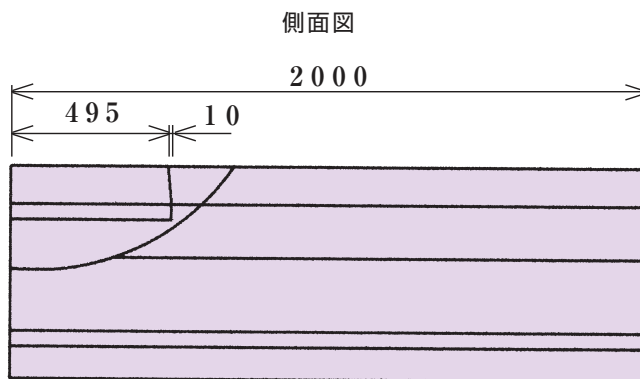
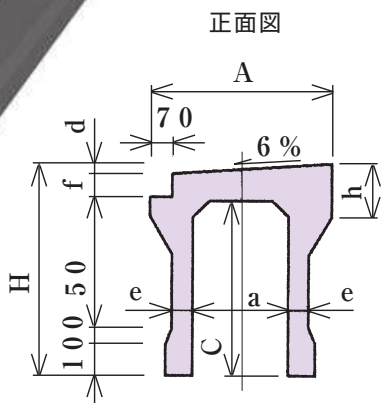
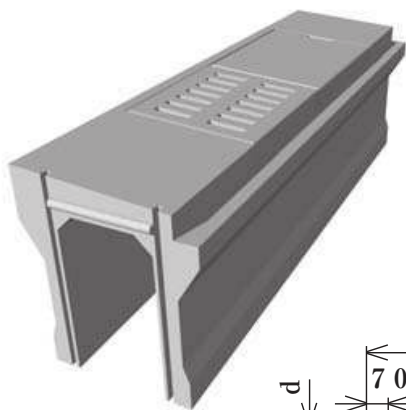

寸法表

呼び名	参考重量 (kg)	寸法 (mm)							
		A	C	H	a	e	h	d	f
300× 300	464	570	350	470	300	65	170	34	74
× 400	535		450	570					
× 500	602		550	670					
× 600	671		650	770					
× 700	740		750	870					
× 800	809		850	970					
× 900	878		950	1070					
× 1000	947		1050	1170					
× 1100	1016		1150	1270					
× 1200	1085		1250	1370					
400× 400	574		670	450					
500	640	550		680					
600	708	650		780					
700	775	750		880					
800	842	850		980					
900	910	950		1080					
1000	977	1050		1180					
500× 500	769	770	550	700	500	75	200	34	74
× 600	841		650	800					
× 700	919		750	900					
× 800	996		850	1000					

# KS側溝Ⅱ型スロープ蓋 T-25 (受)

kumafuji

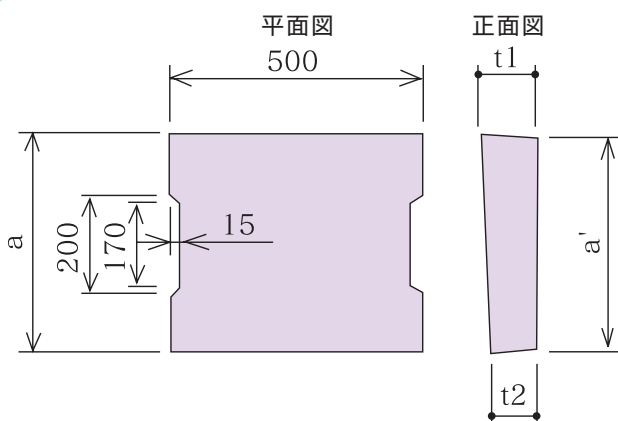

寸法表

単位(mm)

呼び名	参考重量 (kg)	a	a'	t1	t2
300	55	440	430	115	90
400	72	540	530	128	95
500	100	640	630	147	116

## ●規格

### 頂版プレセット製品

工場で頂版を仮設固定し、上面閉塞のスリット付門型側溝として現場納入されます。プレセット頂版は粘着シートのみで止めてあり頂版の一時取外し、片開きは簡単です。

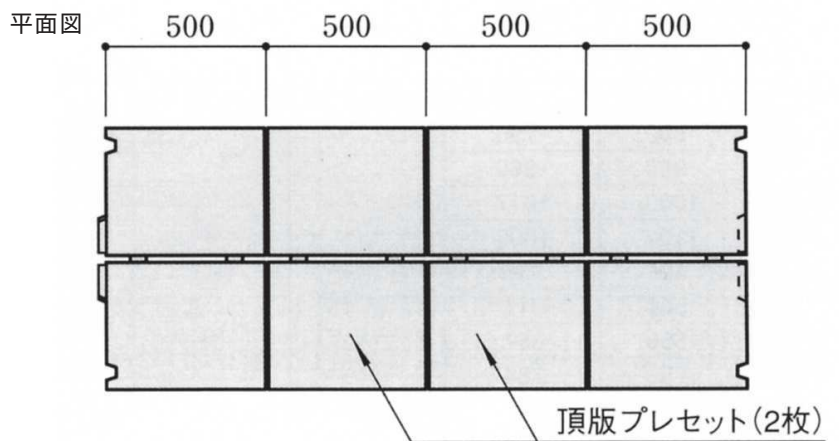
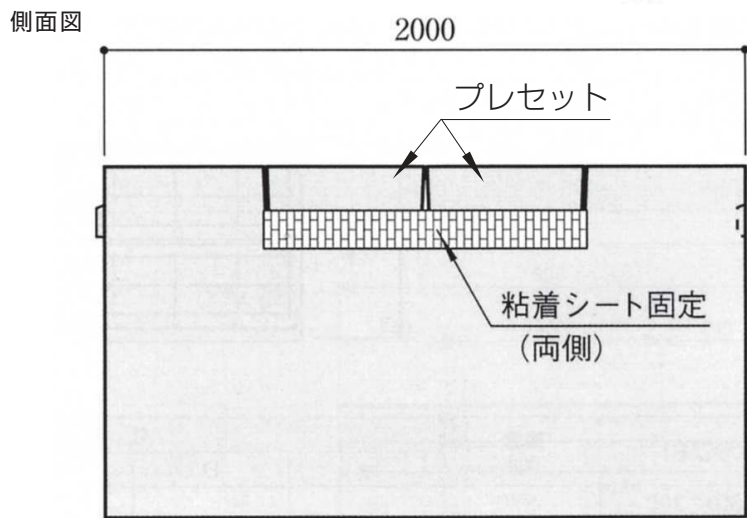
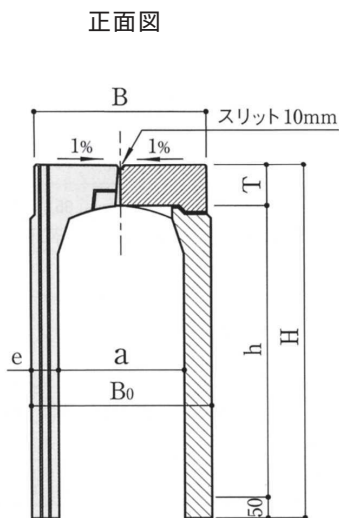
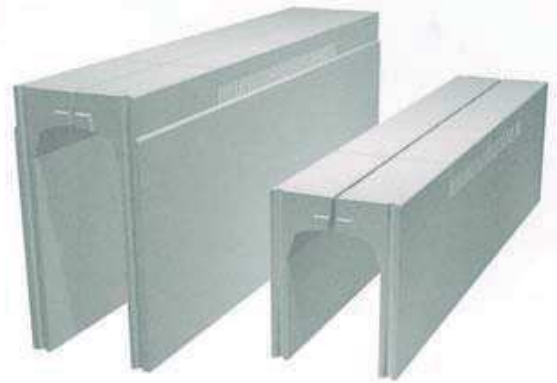

寸法表

呼び名 a×h	参考重量 (kg)	寸 法 (mm)				
		B	B <sub>0</sub>	H	T	e
300 × 300	424	410	430	450	100	65
300 × 400	486	410	430	550	100	65
300 × 500	548	410	430	650	100	65
300 × 600	610	410	430	750	100	65
300 × 700	742	410	450	850	100	75
300 × 800	814	410	450	950	100	75
300 × 900	886	410	450	1050	100	75
300 × 1000	1058	410	470	1150	100	85
300 × 1100	1139	410	470	1250	100	85
300 × 1200	1220	410	470	1350	100	85



## ●規格

縦断用 1種

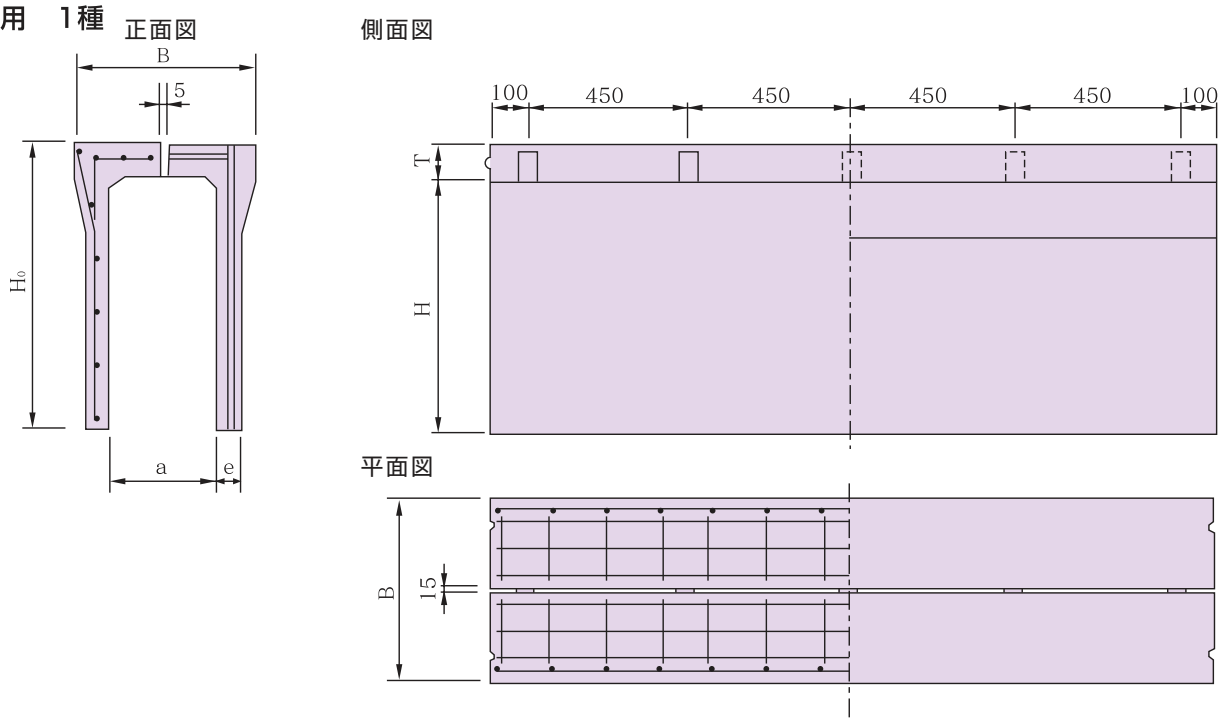

寸法表

呼び名	重量 (kg)	寸法 (mm)					
		a	B	H	H <sub>0</sub>	T	e
300×300	370	300	500	300	395	95	50
400	445			400	495		
500	496			500	595		
600	599			600	695		
700	659			700	795		
800	790			800	895		
900	860			900	995		
1000	1017			1000	1095		
1100	1096			1100	1195		
400×400	536			400	610		
500	611	500	610				
600	667	600	710				
700	784	700	810				
800	849	800	910				
900	994	900	1010				
1000	1069	1000	1110				
1100	1240	1100	1210				
1200	1324	1200	1310			90	

## ●規格

可変フレーム

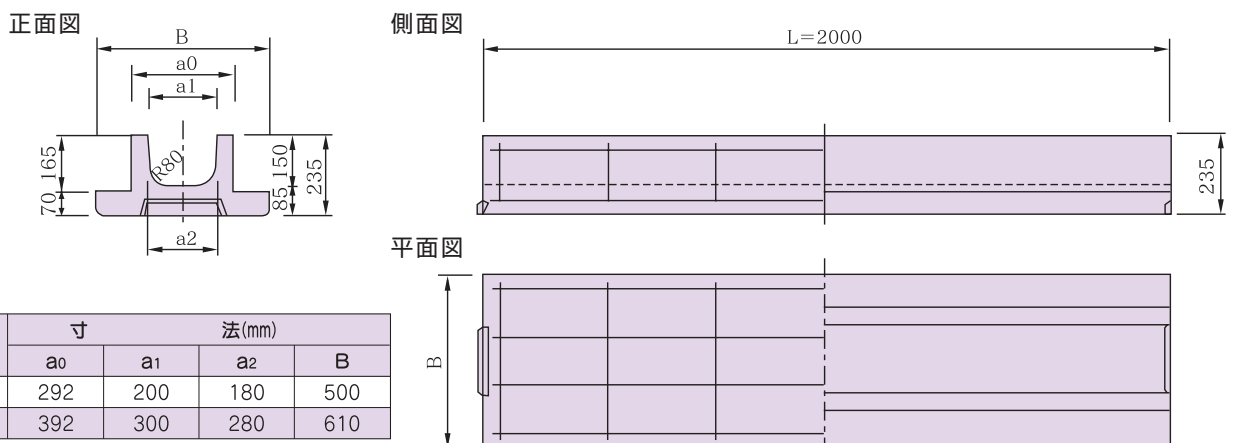

寸法表

呼び名	重量 (kg)	寸法 (mm)			
		a <sub>0</sub>	a <sub>1</sub>	a <sub>2</sub>	B
300	276	292	200	180	500
400	320	392	300	280	610

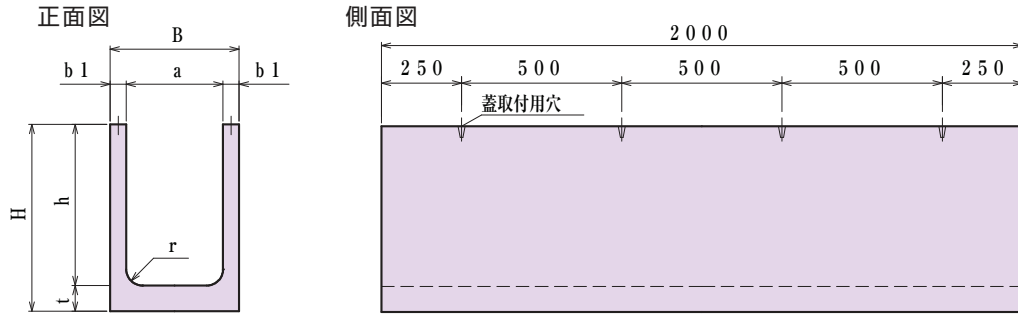

寸法表 単位(mm)

呼び名	参考重量(kg)	a	h	b1	B	t	H	r
300×300	309	300	300	50	400	80	380	50
400	358	300	400	50	400	80	480	50
500	407	300	500	50	400	80	580	50
600	456	300	600	50	400	80	680	50
700	505	300	700	50	400	80	780	50
800	554	300	800	50	400	80	880	50

## ●かんたん側溝の豊富なタイプ

グレーチング仕様 フラット型  
参考重量：105kg

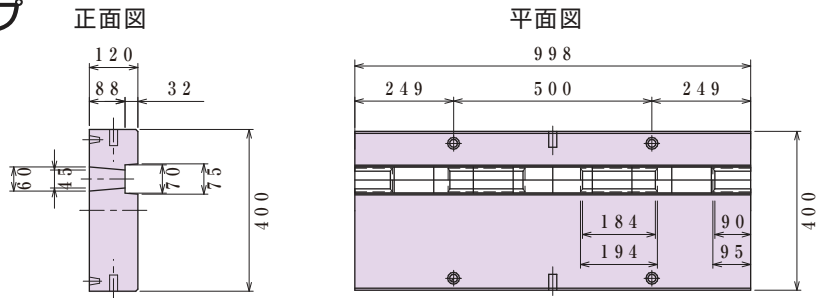

グレーチング仕様 縁石付  
参考重量：170kg

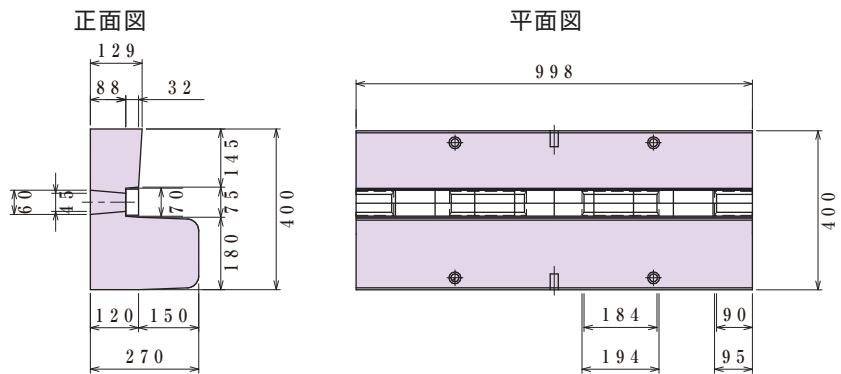

## ●用途に応じた豊富な蓋版



**[1] 緑石付きスリット型 (マウンドアップ用)**  
15mm幅のスリットが連続しています。



**[2] 緑石付きグレーチング型 (マウンドアップ用)**  
60mm幅のグレーチングが連続しています。

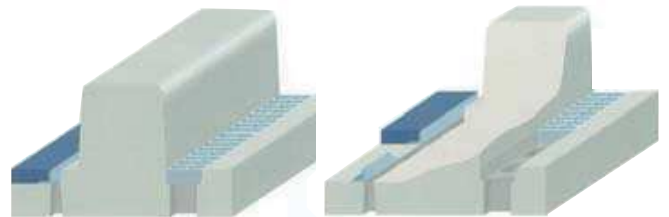

**[3] 緑石付き両面取水型**  
歩道側は15mm幅のスリット、車道側は60mmのグレーチング構造です。  
一つの側溝で歩道と車道の両側から取水できます。



**[4] スリット型**  
側溝端部に15mm幅のスリットが連続しています。



**[5] グレーチング型**  
側溝端部に60mm幅のスリットが連続しています。



**[6] 舗装用グレーチング型**  
蓋版の表面を舗装できます。

※緑石付き蓋版は、マウンドアップ用、ハーフマウンド用、切り下げ用、横断用、緑石分離用があります。その他、規格以外の蓋版も用途に合わせて制作できます。

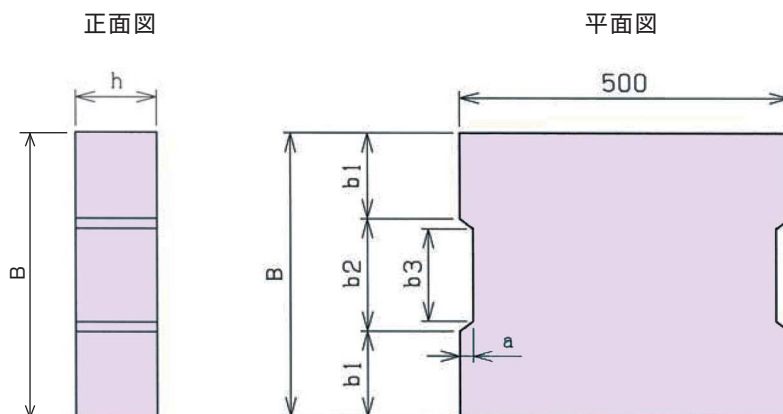

県 I 型寸法表

呼び名	重量 (Kg)	寸法(mm)					
		B	h	b <sub>1</sub>	b <sub>2</sub>	b <sub>3</sub>	a
250用	38	320	100	75	170	140	15
300用	44	370	100	100	170	140	15
350用 <sup>ⓐ</sup>	50	420	100	125	170	140	15

熊本県型寸法表<sup>ⓐ</sup>

呼び名	重量 (Kg)	寸法(mm)						
		B	h	b <sub>1</sub>	b <sub>2</sub>	b <sub>3</sub>	a	
県型	1	64	430	120	130	170	140	20
	2	77	430	150	130	170	140	20
	3	76	530	120	180	170	140	20

熊本市型寸法表<sup>ⓐ</sup>

呼び名	重量 (Kg)	寸法(mm)						
		B	h	b <sub>1</sub>	b <sub>2</sub>	b <sub>3</sub>	a	
市型	1	59	410	120	105	200	170	15
	2	73	510	120	155	200	170	15

国土交通省型寸法表<sup>ⓐ</sup>

呼び名	重量 (Kg)	寸法(mm)						
		B	h	b <sub>1</sub>	b <sub>2</sub>	b <sub>3</sub>	a	
C-7型	1	53	430	100	145	140	100	20
	2	65	530	100	195	140	100	20
	3	92	630	120	245	140	100	20
C-3型	1	68	430	130	145	140	100	20
	2	85	530	130	195	140	100	20
	3	118	630	150	245	140	100	20
C-2型	1	58	430	110	145	140	100	20
	2	78	530	120	195	140	100	20
	3	101	630	130	245	140	100	20

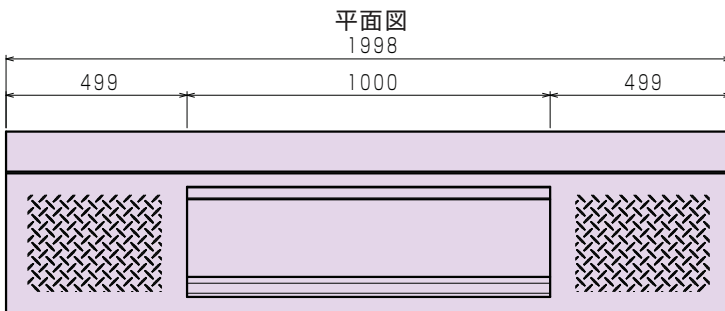
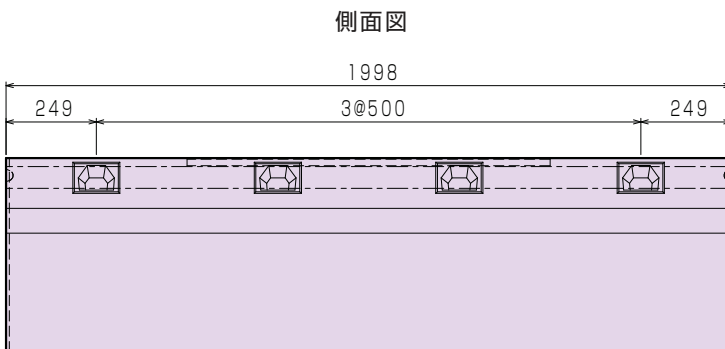
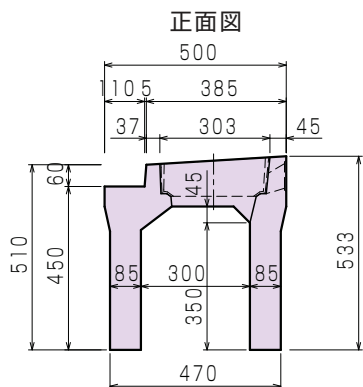

寸法表

呼び名	参考重量 (kg)	寸法 (mm)							
		W	H	H1	H2	B	B1	t1	b
300 × 300	522	300	300	450	534	485	80	85	470
300 × 400	604	300	400	550	634	485	80	85	470
300 × 500	686	300	500	650	734	485	80	85	470
300 × 600	768	300	600	750	834	485	80	85	470
300 × 700	850	300	700	850	934	485	80	85	470
300 × 800	932	300	800	950	1034	485	80	85	470
300 × 900	1014	300	900	1050	1134	485	80	85	470
300 × 1000	1096	300	1000	1150	1234	485	80	85	470
300 × 1100	1178	300	1100	1250	1334	485	80	85	470
300 × 1200	1260	300	1200	1350	1434	485	80	85	470

# 街路型落蓋側溝 (300×300)

本体参考重量：455kg

蓋板参考重量：33kg

