

FM柵 (不二式グレーチング付集水柵)

熊本不二コンクリート工業株式会社

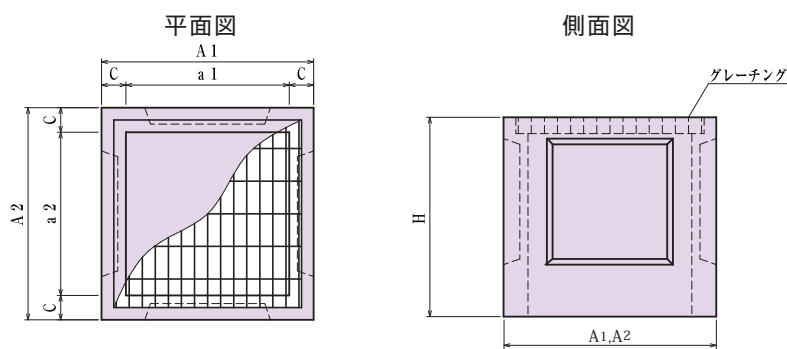

寸法表 C=150 T-25

単位(mm)

呼び名	参考重量(kg)	A ₁	A ₂	a ₁	a ₂	H (基本高)	H範囲
FM-30	435	600	600	300	300	700	400~ 700
FM-30×40 [Ⓢ]	483	600	700	300	400	700	400~ 700
FM-30×50 [Ⓢ]	531	600	800	300	500	700	400~ 700
FM-30×60 [Ⓢ]	580	600	900	300	600	700	400~ 700
FM-35	483	650	650	350	350	700	400~ 700
FM-35×60 [Ⓢ]	604	650	900	350	600	700	400~ 700
FM-40	531	700	700	400	400	700	400~1,000
FM-40×50 [Ⓢ]	580	700	800	400	500	700	400~ 700
FM-40×60 [Ⓢ]	628	700	900	400	600	700	400~ 700
FM-45	662	750	750	450	450	800	500~1,000
FM-50	718	800	800	500	500	800	500~1,500
FM-50×70 [Ⓢ]	1,035	800	1,000	500	700	1,000	700~1,500
FM-60	1,035	900	900	600	600	1,000	700~1,500
FM-70	1,408	1,000	1,000	700	700	1,200	900~1,500
FM-80	1,573	1,100	1,100	800	800	1,200	900~1,500
FM-90 [Ⓢ]	2,174	1,200	1,200	900	900	1,500	1,200~1,500
FM-100 [Ⓢ]	2,381	1,300	1,300	1,000	1,000	1,500	1,200~1,500
FM-120 [Ⓢ]	2,795	1,500	1,500	1,200	1,200	1,500	1,200~1,500

II型寸法表 C=200 T-25[Ⓢ]

単位(mm)

呼び名	参考重量(kg)	A ₁	A ₂	a ₁	a ₂	H (基本高)	H範囲
FM40-II	773	800	800	400	400	700	400~1,000
FM50-II	1,288	900	900	500	500	1,000	700~1,500
FM60-II	1,472	1,000	1,000	600	600	1,000	700~1,500
FM70-II	1,987	1,100	1,100	700	700	1,200	900~1,500
FM80-II	2,208	1,200	1,200	800	800	1,200	900~1,500
FM90-II	2,429	1,300	1,300	900	900	1,200	900~1,500
FM100-II	3,312	1,400	1,400	1,000	1,000	1,500	1,200~1,500
FM120-II	3,864	1,600	1,600	1,200	1,200	1,500	1,200~1,501

●スロープ型としても製造出来ます。●コンクリート蓋としても製造出来ます。●高さ・穴位置等相談下さい。●上記以外のサイズ一要相談

柵用集水蓋[Ⓢ] ※縦断載荷時 T-25 横断載荷時 T-6

kumafuji

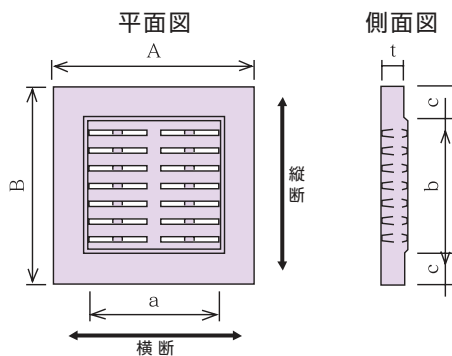

寸法表

単位(mm)

呼び名	参考重量(kg)	A	B	a	b	c	t
FM-30	15	395	395	253	273	61	44
35	25	466	466	324	344	61	50
40	28	500	500	358	378	61	50
45	41	572	572	430	450	61	55
50	46	607	607	465	485	61	55
60	57	713	713	571	591	61	60

本体

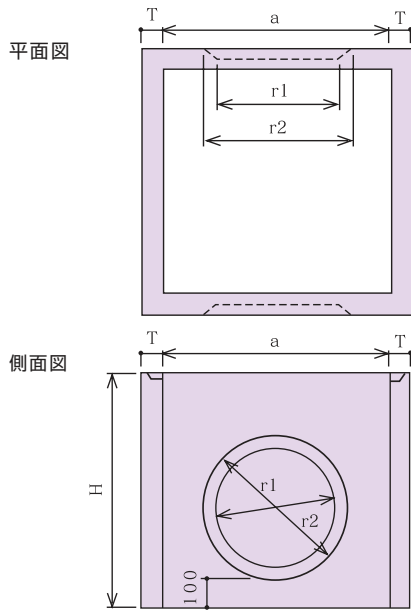

蓋板

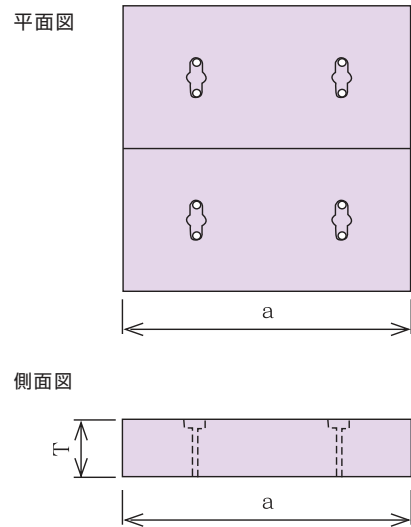

寸法表

単位(mm)

呼び名	寸法	重量 (kg)	厚さ T	内径 a	高さ H	外径 r2	内径 r1	ビューム管取付
3号桧	750×750×800	343	70	750	800	490	470	350~400
	調整桧	112	70	750	200	—	—	
	蓋	190	100	890	—	—	—	
4号桧	1000×1000×1000	693	80	1000	1000	800	700	φ600以上
	調整桧	149	80	1000	200	—	—	
	蓋	323	100	1160	—	—	—	

L型桧

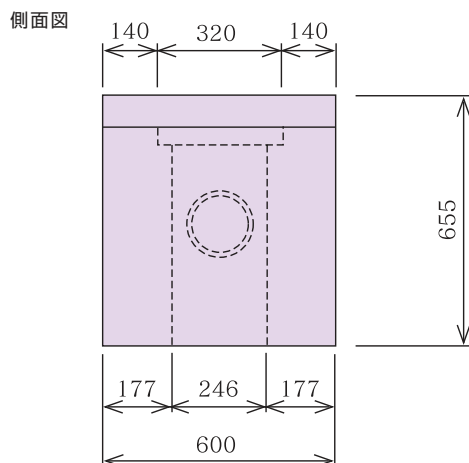
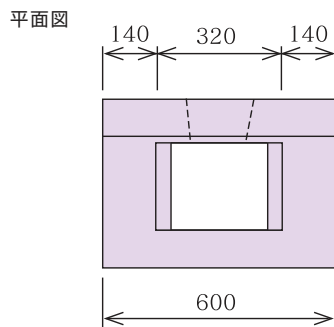

参考重量 304kg

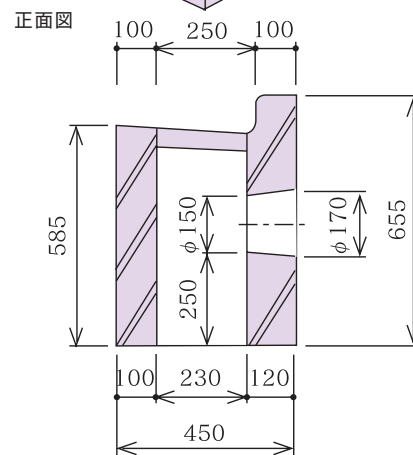
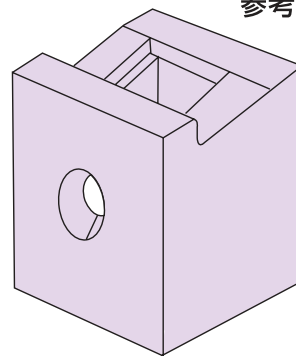

参考重量 175kg

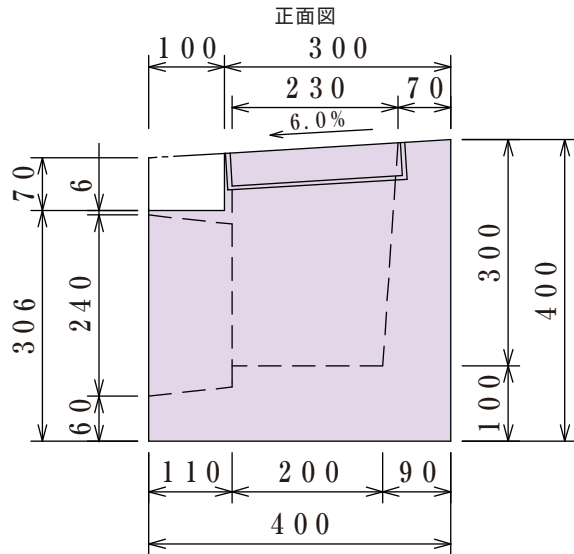
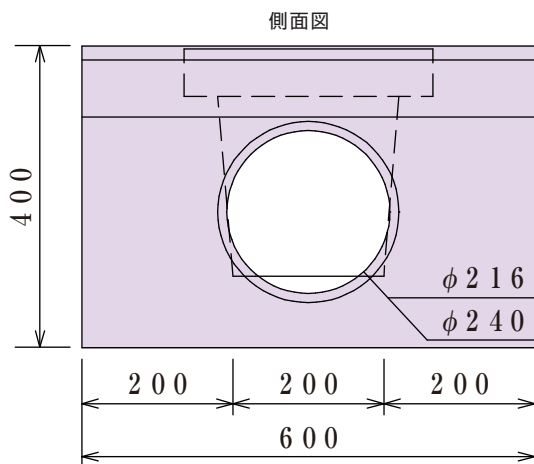
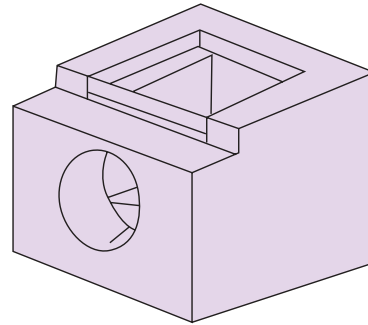
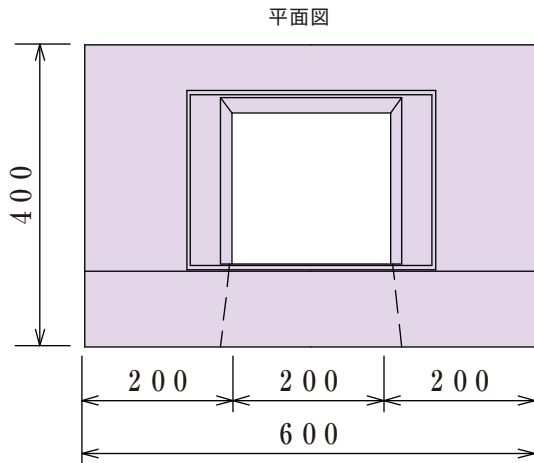

集水枡用

各種集水枡 (受)

kumafuji

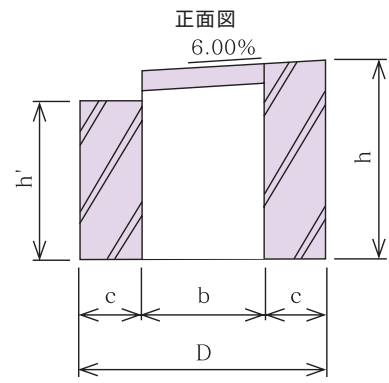
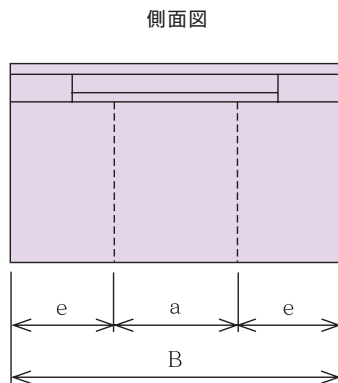
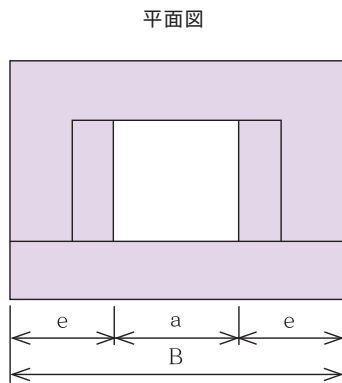

寸法表

単位 (mm)

サイズ	参考重量(kg)	a	b	c	e	h	h'	B	D	天端勾配
300×300×500	440	300	300	150	250	500	400	800	600	6%
300×400×685	441	400	300	150	150	685	587	700	600	6%
400×500×650	505	500	400	150	150	650	555	800	700	6%
300×400×530	430	400	300	200	200	530	430	800	700	6%
400×500×850	630	500	400	150	150	850	757	800	700	6%
350×400×650	419	400	350	150	150	650	560	700	650	6%
300×600×755	568	600	300	150	150	755	550	900	600	6%
300×400×650	307	400	300	100/200	100	650	565	600	600	6%
300×400×680	306	400	300	120	120	680	—	640	540	0(フラット)

上記サイズ以外でも御相談に応じます

平面図

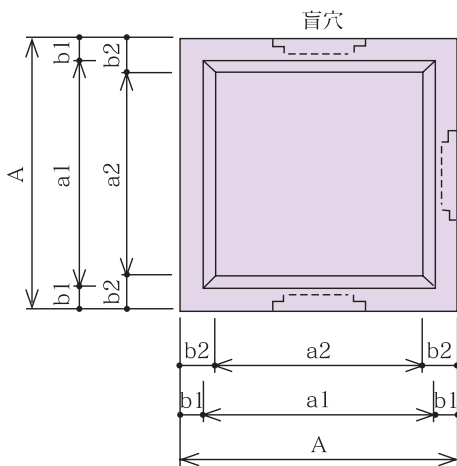

側面図

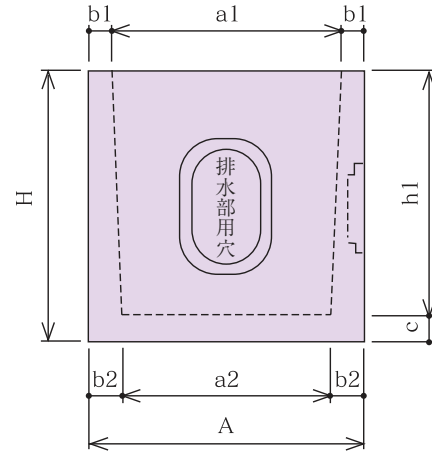

本体寸法表

単位(mm)

呼び名	底なし重量	底付重量	A	a1	a2	b1	b2	C	H	h1
240	31	37	300	240	220	30	40	30	330	300
300	43	53	360	300	270	30	45	35	395	360
360	69	86	430	360	330	35	50	40	455	415
400	80	101	470	400	360	35	50	50	500	450
450	106	135	520	450	410	35	55	45	550	505
500	153	189	580	500	450	40	65	45	605	560
600	221	282	680	600	540	40	70	55	710	655

排水溜桧蓋

平面図

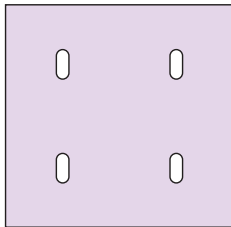

側面図

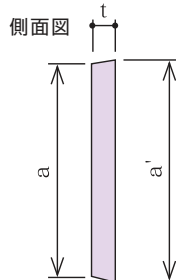

桧蓋寸法表

単位(mm)

呼び名	重量	a	a'	t
240	7	295	300	30
300	10	350	360	35
360	14	410	420	40
400	21	460	470	40
450	26	510	520	45
500	37	570	580	50
600	55	670	680	55

※グレーチング蓋対応可

溜桧蓋受

平面図

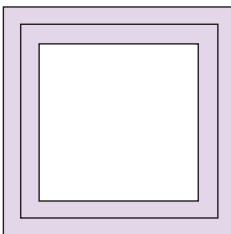

側面図

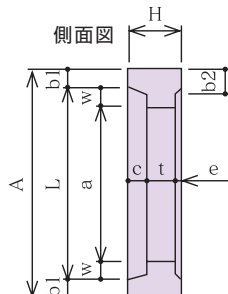

桧蓋受寸法表

単位(mm)

呼び名	重量kg	A	a	b1	b2	c	e	H	L	t	w
240	17	380	240	35	35	30	10	100	310	60	35
300	19	440	300	35	35	35	10	100	370	55	35
360	22	500	360	35	35	40	10	100	430	50	35
400	28	550	400	35	35	40	10	100	480	50	40
450	46	650	450	40	40	48	10	110	570	52	40
500	47	700	500	45	45	53	10	110	610	47	45
600	54	800	600	45	45	58	10	110	710	42	45

補助桧

平面図

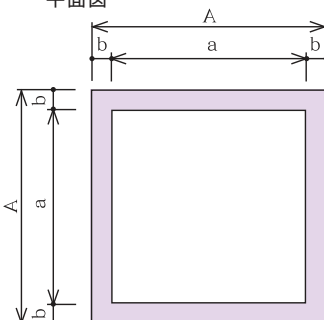

側面図

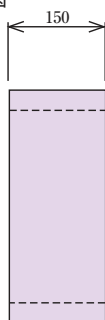

補助桧寸法表

単位(mm)

呼び名	重量	A	a	b
240	12	300	240	30
300	14	360	300	30
360	20	430	360	35
400	22	470	400	35
450	24	520	450	35
500	31	580	500	40
600	37	680	600	40

角形溜桝（宅地用）

本 体

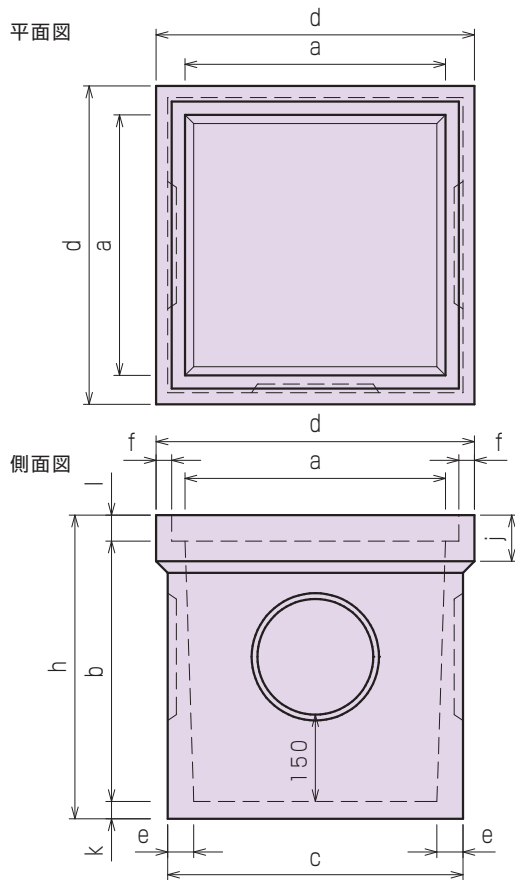

雨 水 蓋

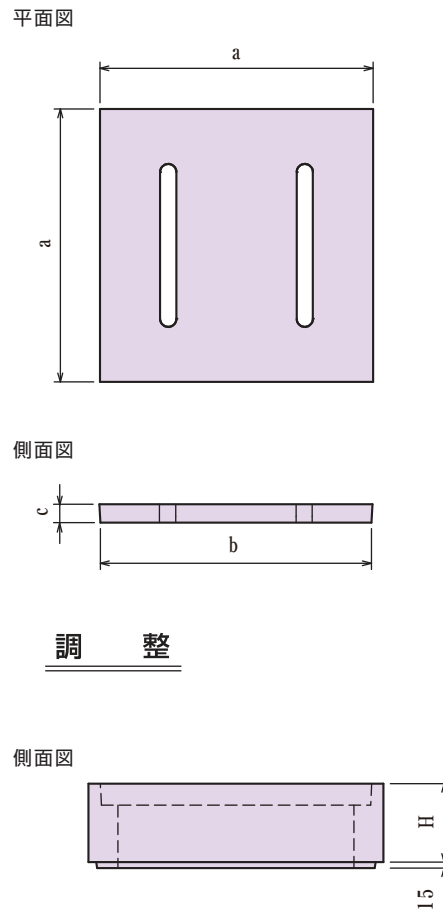

調 整

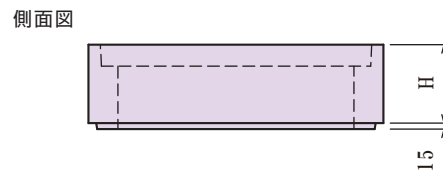

溜桝 本体 寸法表

単位(mm)

呼び名	寸 法(mm)											重 量 (kg)
	a	b	c	d	e	f	h	j	k	l	r	
180	180	240	220	270	20	25	290	60	20	30	50	15
240	240	300	290	330	25	25	355	65	25	30	45	30
300	300	360	350	390	25	25	415	80	25	30	70	43
360	360	420	420	460	30	27	495	80	30	40	100	78
420	420	420	480	520	30	27	495	80	30	45	100	90
450	450	450	510	550	30	27	525	80	30	45	100	106
600	600	600	670	750	35	30	690	100	35	55	100	237

溜桝 蓋 寸法表

単位(mm)

呼び名	寸 法(mm)			重 量 (kg)
	a	b	c	
180	210	205	30	3
240	270	265	30	5
300	330	325	30	8
360	395	390	40	14
420	455	450	45	21
450	485	480	45	24
600	680	670	55	55

※グレーチング蓋対応可

溜桝 調整 寸法表

単位(mm)

呼び名	寸 法(mm)	
	H	重 量 (kg)
180	100	8
	150	12
240	100	11
	150	16
300	100	13
	150	19
360	200	36
420	200	41
450	200	44
600	200	97